

Direct measurement of electromagnetic dipole moments of strange and charm baryons

Nicola Neri

Università degli Studi and INFN Milano

LFC22

Trento, 29 Aug - 2 Sept 2022



European Research Council
Established by the European Commission



SELDOM webpage
 @SeldomTeam

Acknowledgements

- ▶ **LHCb** contributors: S. Aiola, S. Barsuk, N. Conti, F. De Benedetti, A. De Gennaro, J.Fu, L. Henry, Y. Hou, C. Lin, D. Marangotto, F. Martinez Vidal, J. Mazorra, A. Merli, N. Neri, E. Niel, A. Oyanguren, M. Rebollo, P. Robbe, J. Ruiz Vidal, I. Sanderswood, E. Spadaro Norella, A. Stocchi, G. Tonani, Z. Wang
- ▶ **LHCb FITPAN** review members: T. Eric, M. Ferro-Luzzi, G. Graziani, R. Kurt, R. Lindner, C. Parkes, M. Palutan, G. Passaleva, M. Pepe-Altarelli, V. Vagnoni, G. Wilkinson
- ▶ **Contributions** also from: G. Arduini, E. Bagli, L. Bandiera, O.A. Bezshyyko, L. Burmistrov, G. Cavoto, D. De Salvador, A.S. Fomin, S.P. Fomin, F. Galluccio, M. Garattini, M.A. Giorgi, V. Guidi, A.Yu. Korchin, I.V. Kirillin, Y. Ivanov, L. Massacrier, V. Mascagna, A. Mazzolari, D. Mirarchi, S. Montesano, A. Natochii, M. Prest, S. Redaelli, W. Scandale, N.F. Shul'ga, E. Vallazza,
- ▶ Interesting **discussions/suggestions**: V. Baryshevsky, V. M. Biryukov

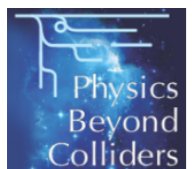

Outline

- ▶ Introduction and physics motivations
- ▶ Experimental method for strange baryons
 - feasibility studies and analyses in progress
- ▶ Experimental method for charm baryons
 - R&D and preparatory studies
- ▶ Summary

Introduction

- ▶ Quantum system

$$\delta = d \frac{q\hbar S}{2m \hbar}$$

$$\mu = g \frac{q\hbar S}{2m \hbar}$$

δ = electric dipole moment (EDM)
 μ = magnetic dipole moment (MDM)

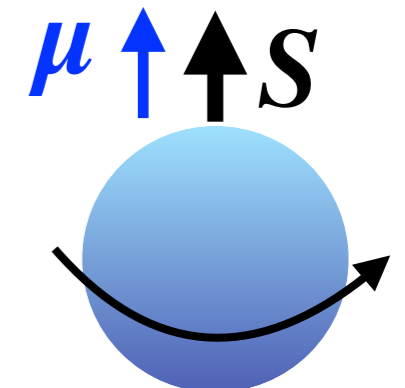
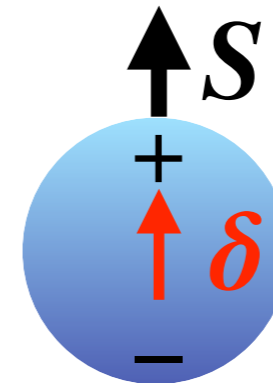

Hamiltonian

$$H = -\mu \cdot B - \delta \cdot E$$

Time reversal, Parity:

$$d\mu_N S \cdot E \xrightarrow{T,P} -d\mu_N S \cdot E$$

The EDM violates T and P and, via CPT theorem, violates CP

	C	P	T
μ	-	+	-
δ	-	+	-
E	-	-	+
B	-	+	-
S	+	+	-

EDM: a probe for CPV beyond the SM

▶ $\mathcal{L}_{CPV} = \mathcal{L}_{CKM} + \mathcal{L}_{\bar{\theta}} + \mathcal{L}_{BSM}$

- SM: negligible CKM contribution; $\bar{\theta}$ -QCD for possible CPV in strong interaction, $\bar{\theta} \lesssim 10^{-10}$ from neutron EDM limit

$$\delta_n \approx (10^{-16} e \text{ cm}) \bar{\theta}$$

Rev. Mod. Phys. **91**, 015001 (2019)

Example of SM CKM contributions

$$\delta_d \propto \text{Im}(V_{tb} V_{td}^* V_{cd} V_{cb}^*) m_d m_c^2 \alpha_s G_F^2 \approx 10^{-34} e \text{ cm}$$

“Long distance” contribution

$$\delta_{n,p} \approx (1 - 6) \times 10^{-32} e \text{ cm}$$

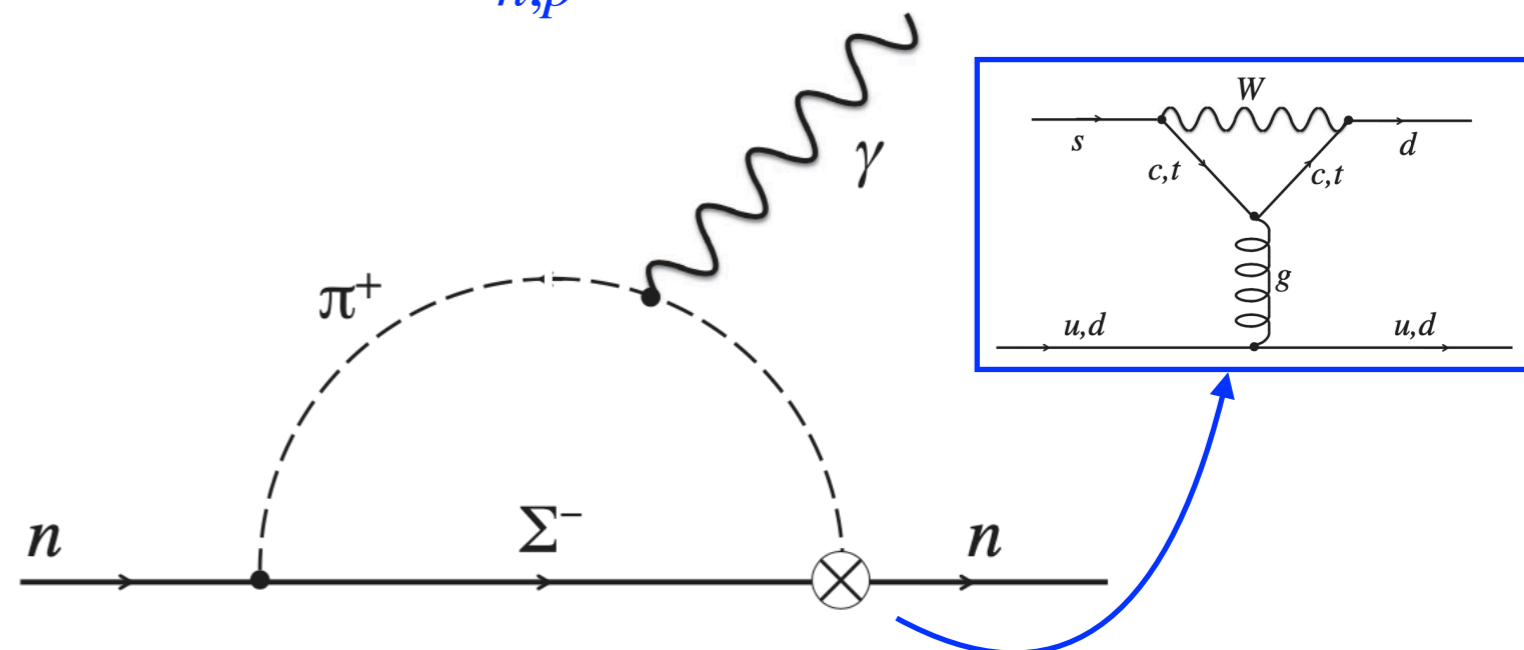
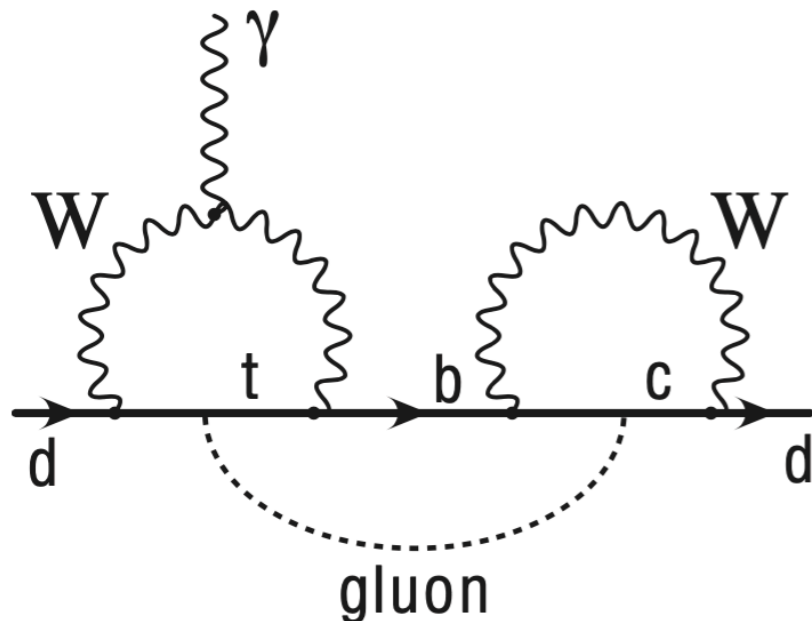

EDM: a probe for CPV beyond the SM

▶ $\mathcal{L}_{CPV} = \mathcal{L}_{CKM} + \mathcal{L}_{\bar{\theta}} + \mathcal{L}_{BSM}$

- BSM : potential large contributions by new physics scale Λ_{NP} and CP-violating phase ϕ_{CPV}

$$\delta_{BSM} \approx (10^{-16} \text{ e cm}) \left(\frac{246 \text{ GeV}}{\Lambda_{NP}} \right)^2 \sin \phi_{CPV} y_f F$$

Examples of BSM contributions

Rev. Mod. Phys. **91**, 015001 (2019)

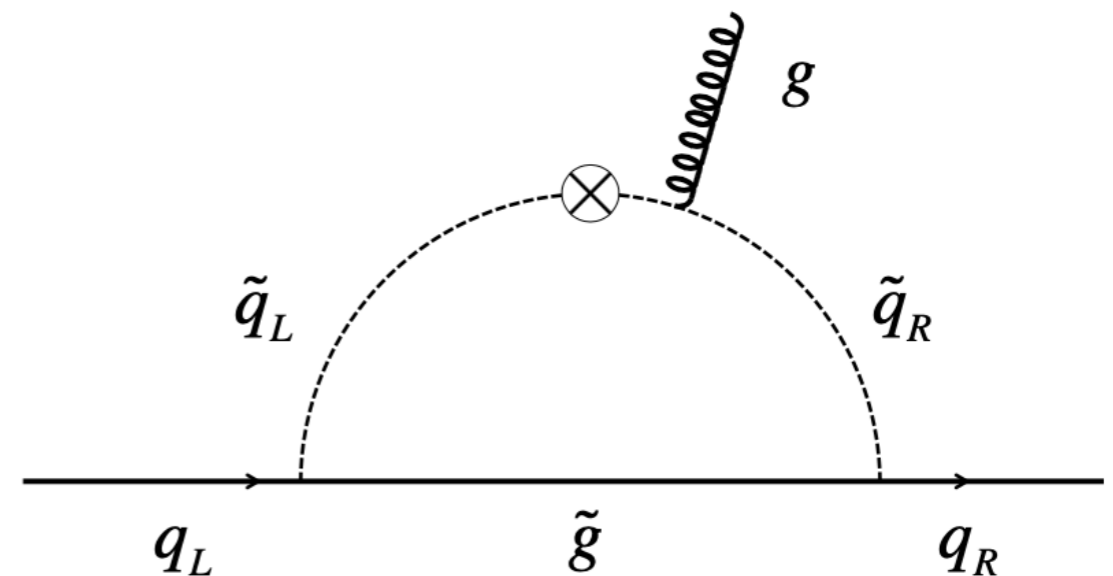
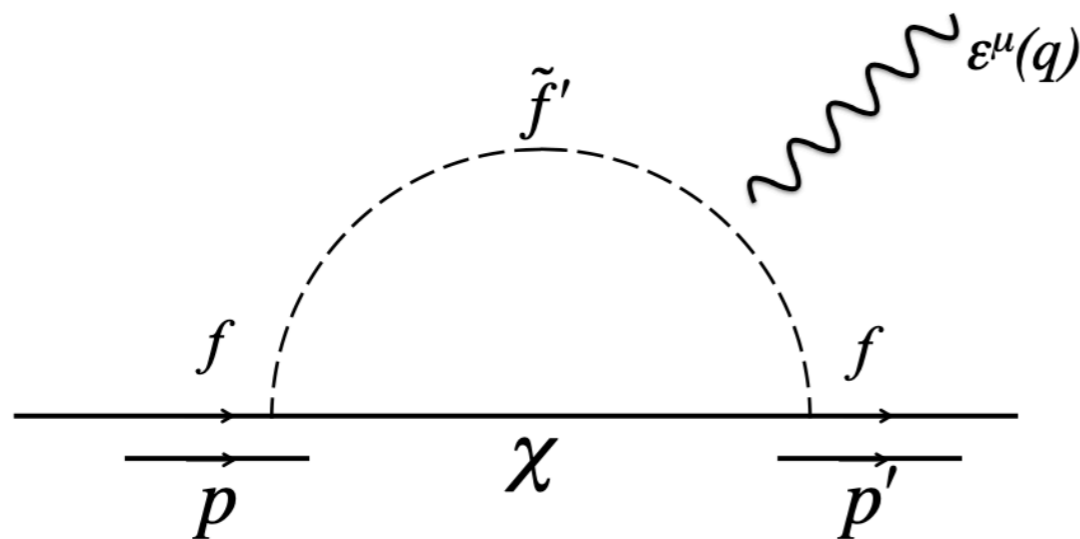

Status of EDM measurements

- ▶ Need to measure many systems to disentangle the underlying source of CPV

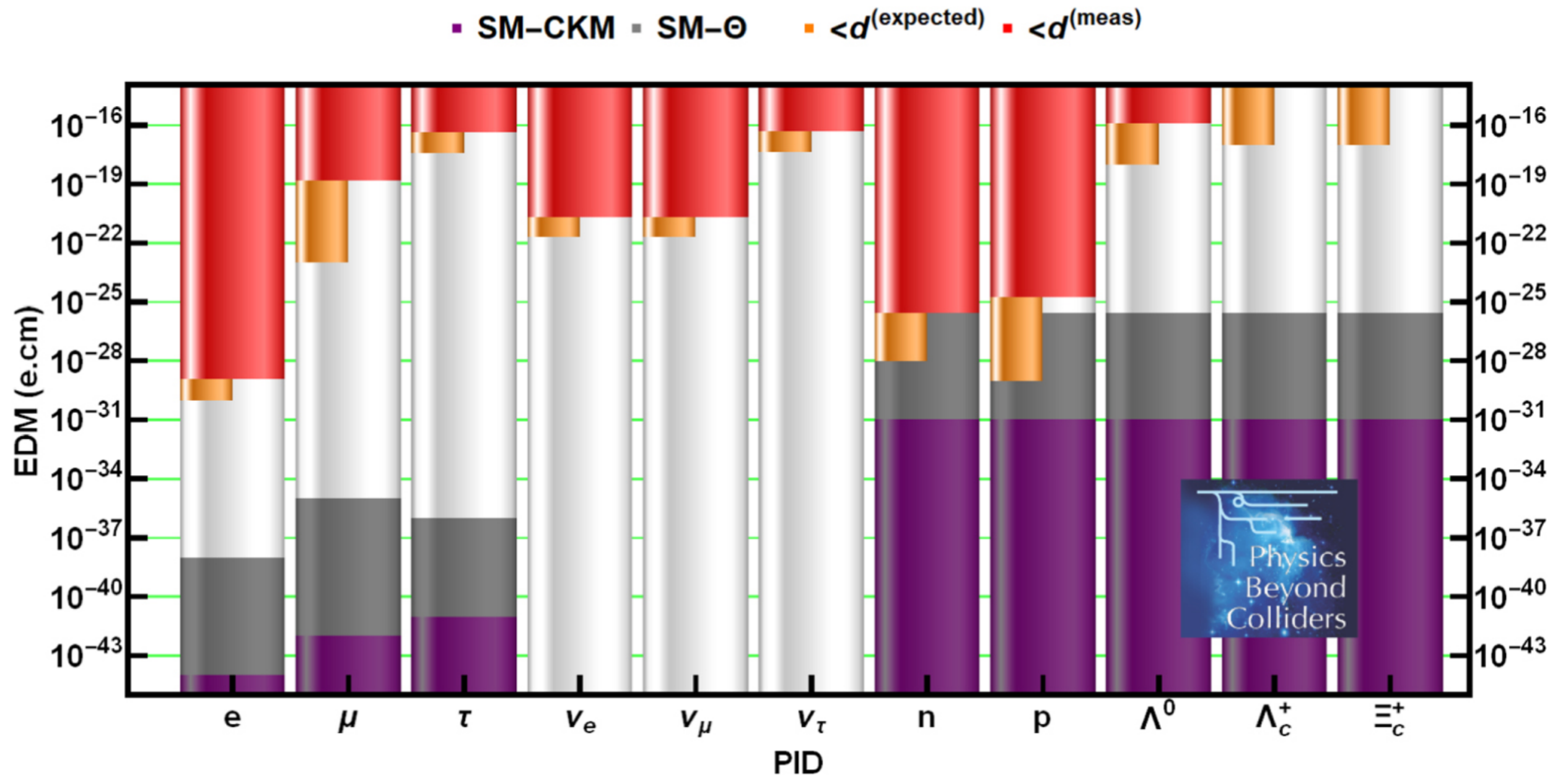

J. Phys. G: Nucl. Part. Phys. **47** (2020) 010501

MDM of baryons

- ▶ No direct measurements for **charm** baryons
- ▶ Further information on **baryon substructure**

$$\mu_{\Lambda_c^+} = g_{\Lambda_c^+} \frac{e\hbar}{2m_{\Lambda_c^+}} \text{ with } g_{\Lambda_c^+} \neq 2 \text{ (not point-like fermion)}$$

- ▶ Experimental anchor points for test of low-energy QCD models, **non-perturbative QCD** dynamics
- ▶ Measurement of MDM of Λ and $\bar{\Lambda}$ **strange** baryons and antibaryons for a **test of CPT symmetry**

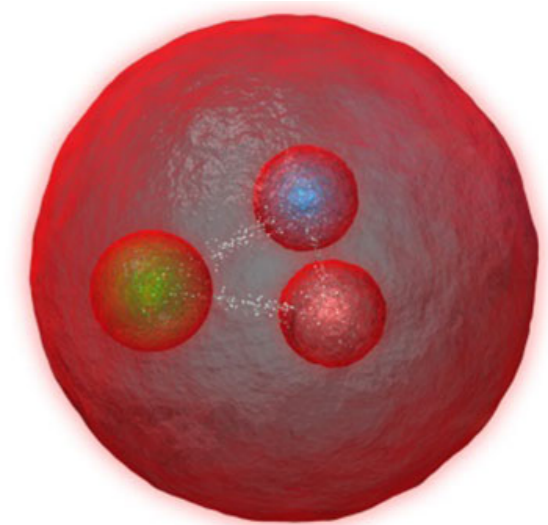
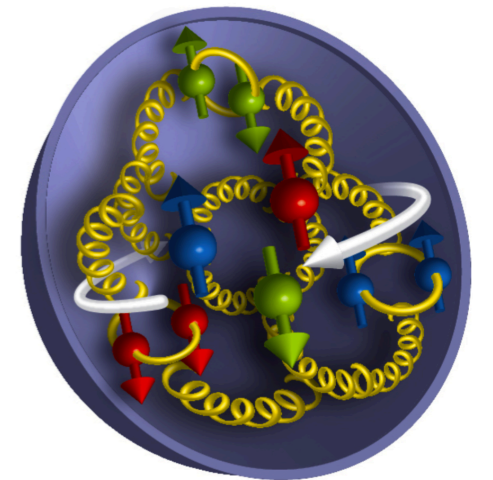

MDM theoretical predictions

In the quark model $\Lambda_c^+ = [ud]c$ $\Xi_c^+ = [us]c$ EPJC 80 (2020) 358
 $\mu_{\Lambda_c^+} = \mu_c$ $\mu_{\Xi_c^+} = \mu_c$ $\mu_c = (0.48 \pm 0.03)\mu_N$

Beyond the quark model: e.g. heavy quark effective theories

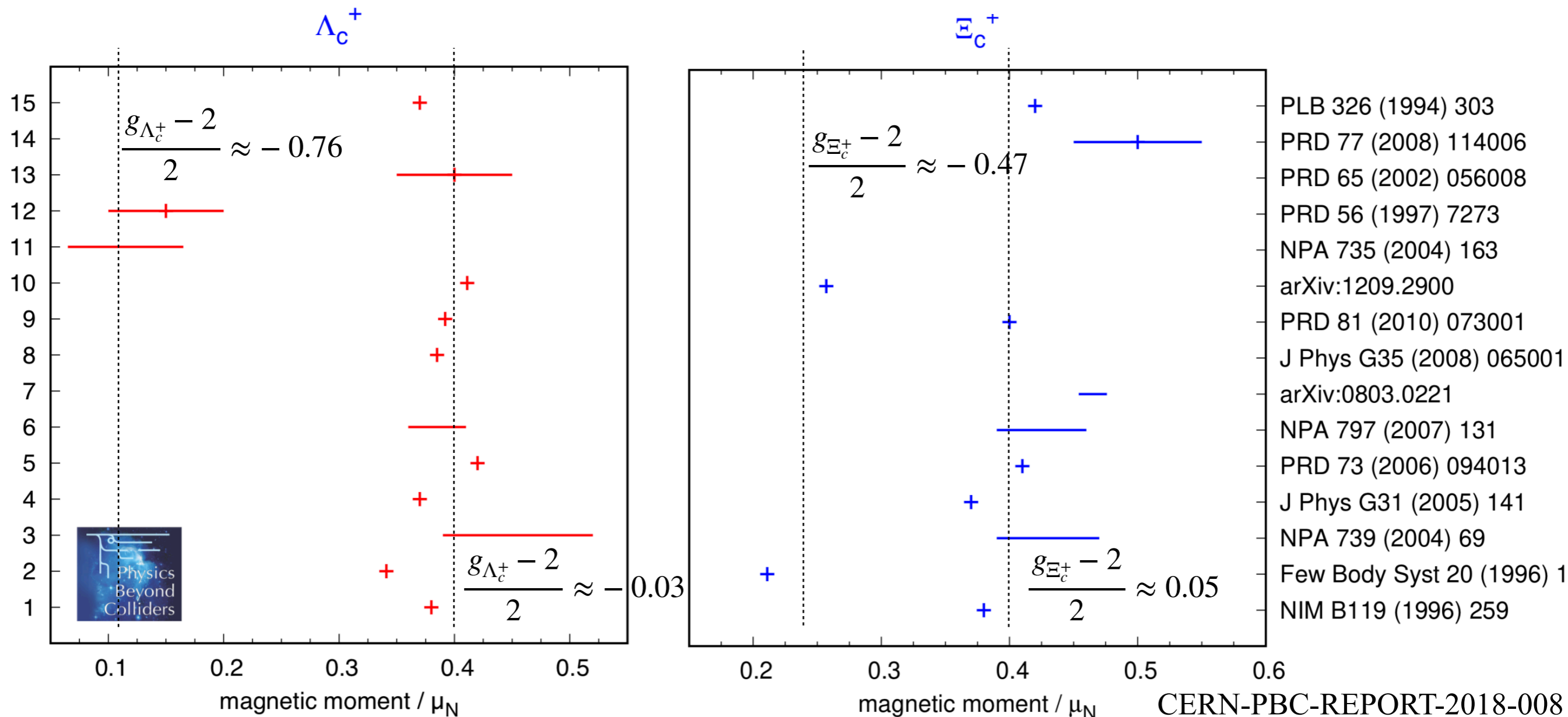

CERN-PBC-REPORT-2018-008

Proposed experimental method for
neutral long-lived Λ baryons in LHCb
 $\tau \approx 10^{-10}$ s

F. J. Botella et al., Eur.Phys.J.C 77 (2017) 181

Status of art for Λ baryon EDM/MDM

- ▶ Current limit on Λ baryon **EDM** $< 1.5 \times 10^{-16} e\text{cm}$ at 95% CL L. Pondrom et al., Phys. Rev. D **23**, 814 (1981)
- ▶ Measurement of **MDM** $\mu_\Lambda = (-0.6138 \pm 0.0047) \mu_N$ but no measurement for $\bar{\Lambda}$ exists Phys.Rev.Lett. 41 (1978) 1348
- ▶ Measurement of MDM of $\bar{\Lambda}$ is needed for a **CPT** test
- ▶ New BESIII measurement of Λ **decay parameter** inconsistent with previous results
 $\alpha = 0.750 \pm 0.009 \pm 0.004$ Nature Phys. 15 (2019) 631-634
- ▶ Need **new measurements** to verify and improve previous results based on wrong α value

Λ baryon precession in the magnet

- ▶ Long-lived Λ baryons can travel through the LHCb **dipole magnet**

- ▶ **Spin precession** occurs in B field

$$\frac{dS}{d\tau} = \boldsymbol{\mu} \times \mathbf{B}^* + \boldsymbol{\delta} \times \mathbf{E}^*$$

- ▶ Select Λ (anti- Λ) from **weak decays**

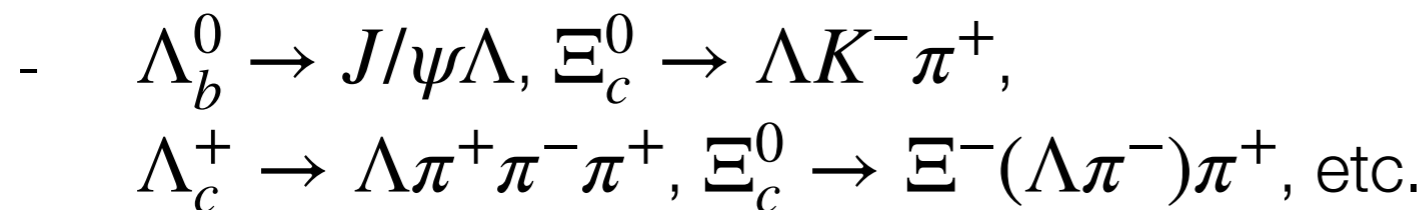

- Large longitudinal **polarisation** (up to 100%) due to parity violation in the weak decay

- ▶ Challenge: reconstruct Λ baryon decays after the magnet using **T tracks**

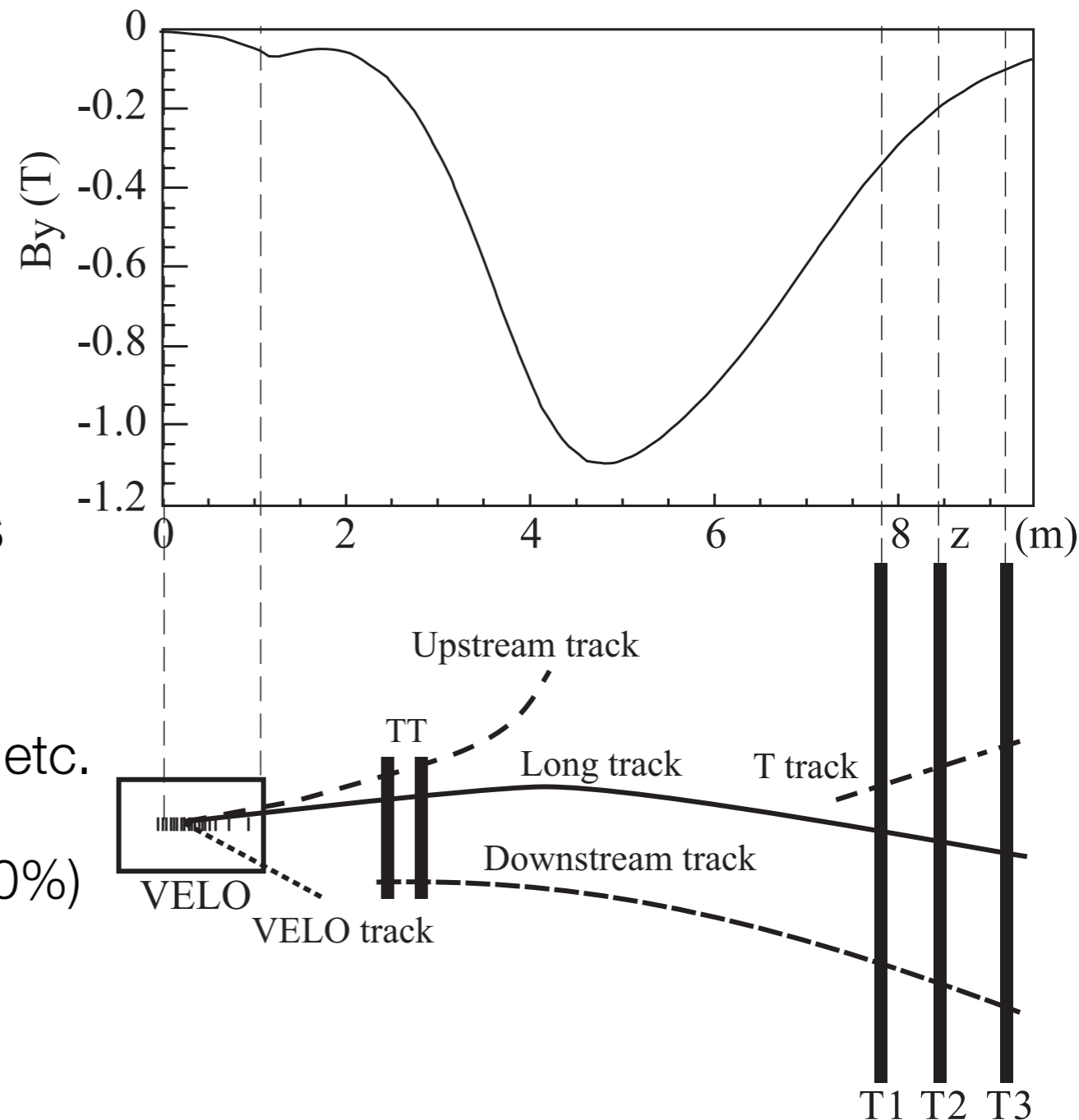

Experimental technique for strange baryons

- ▶ EDM/MDM from spin precession of Λ baryon in LHCb **dipole magnet**

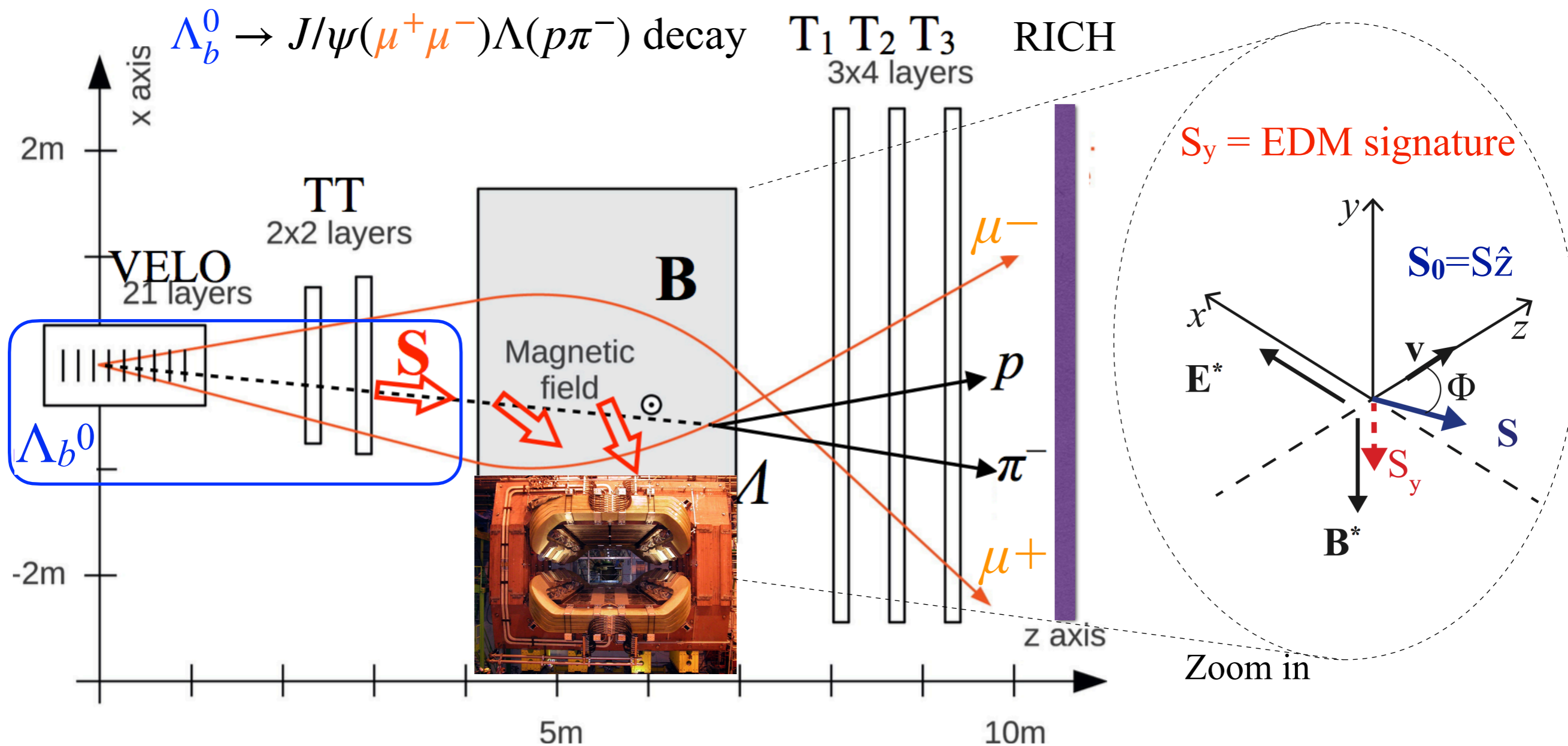

Λ polarised production

Experimental technique for strange baryons

- ▶ **EDM/MDM** from spin precession of Λ baryon in LHCb **dipole magnet**

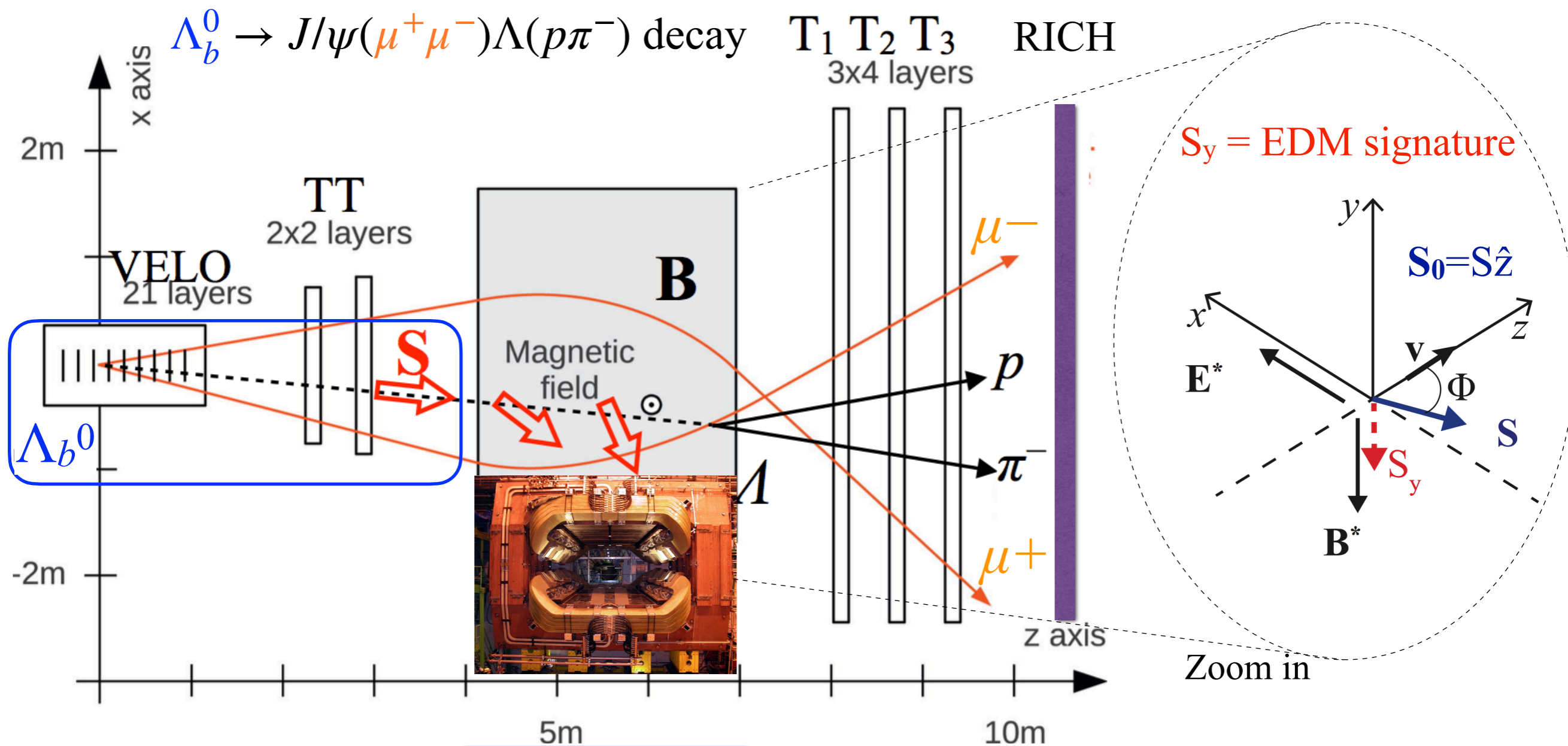

Λ polarised production **spin precession**

Experimental technique for strange baryons

- ▶ EDM/MDM from spin precession of Λ baryon in LHCb **dipole magnet**

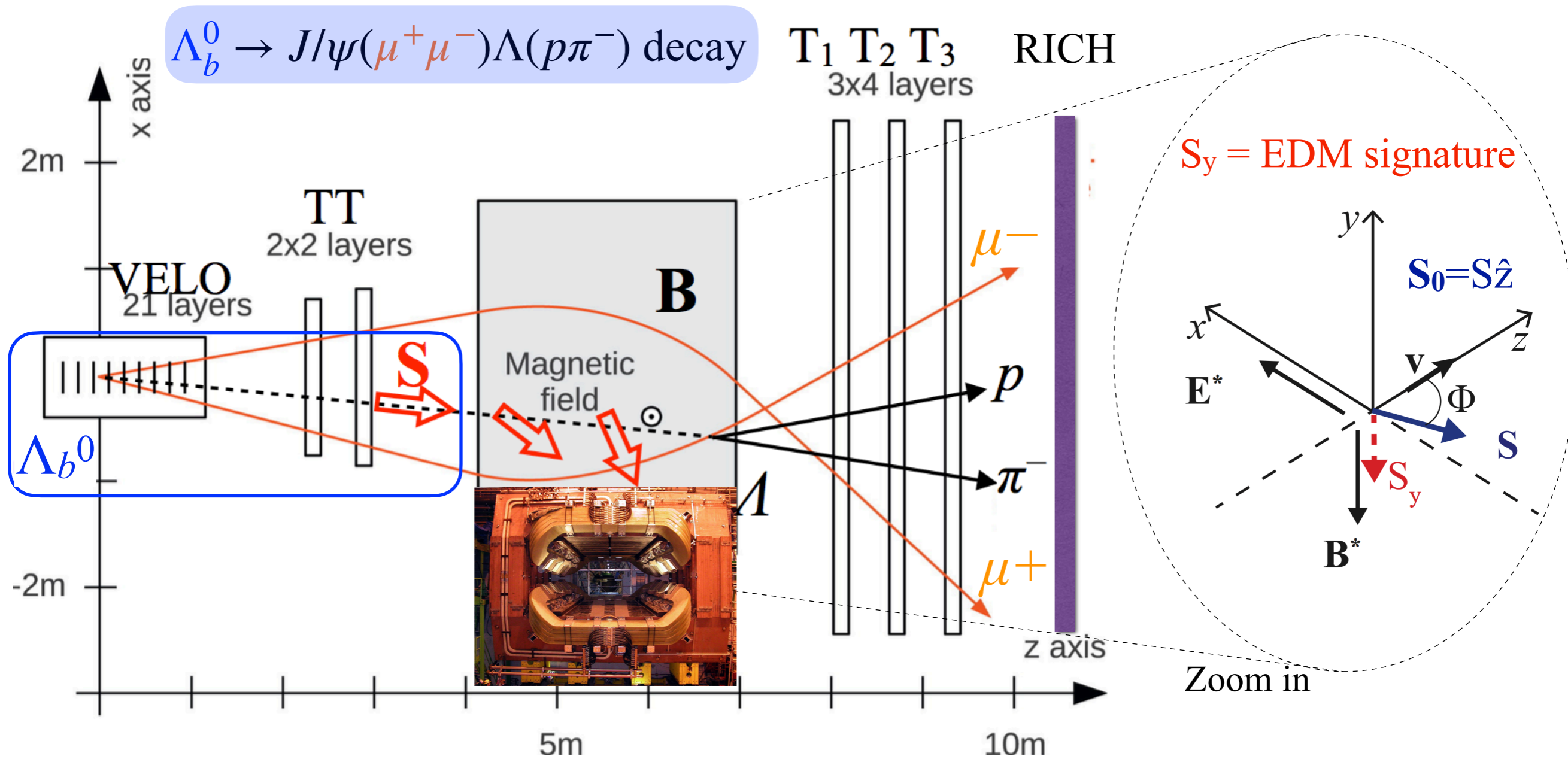

Λ polarised production spin precession event reconstruction

Simulations studies for Λ reconstruction

- ▶ Fit full decay chain $\Lambda_b^0 \rightarrow J/\psi(\mu^+\mu^-)\Lambda(p\pi^-)$ with geom. and kin. constraints
- ▶ Λ decays after the magnet $z \in [6.0-7.6]m$ from IP (**T tracks**)

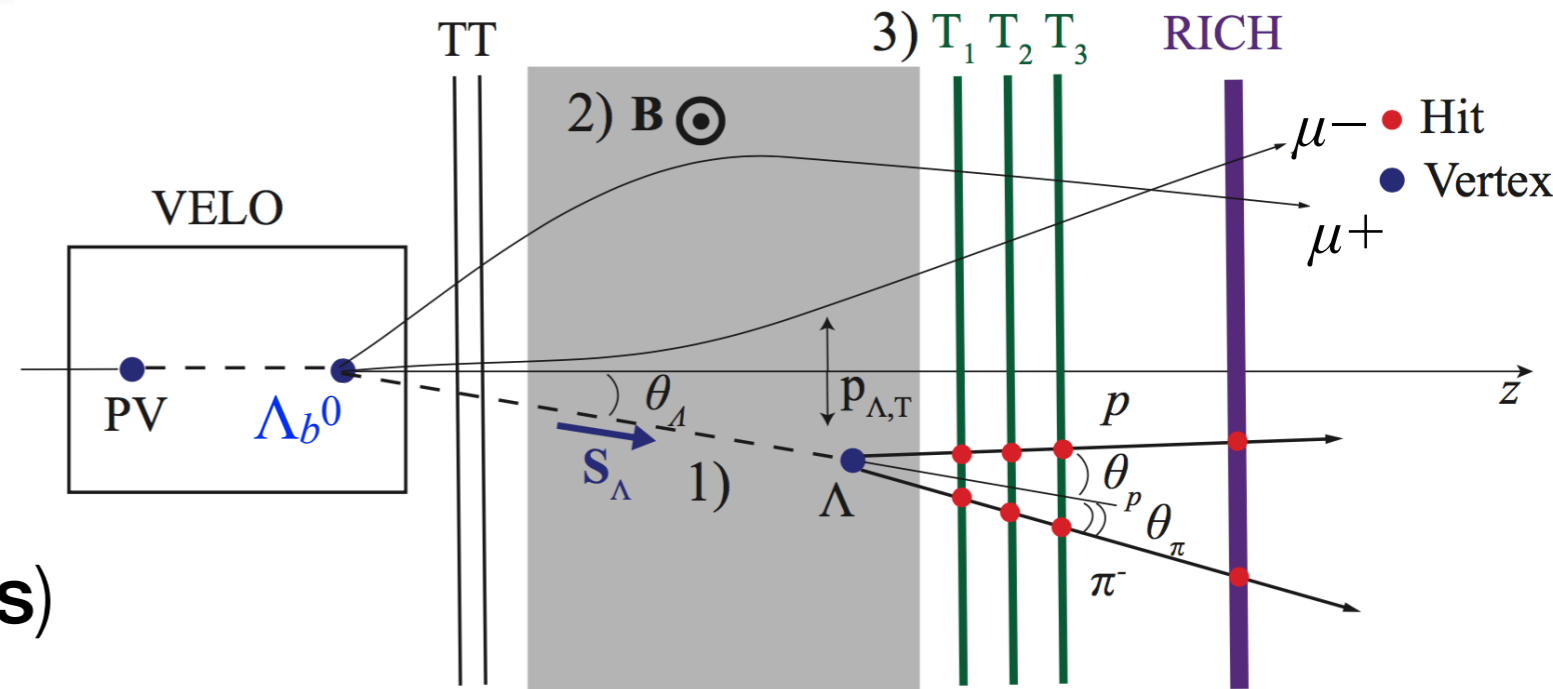

1) Polarized Λ baryons 2) Magnetic field region 3) LHCb detector

LHCb-DP-2022-001
in review

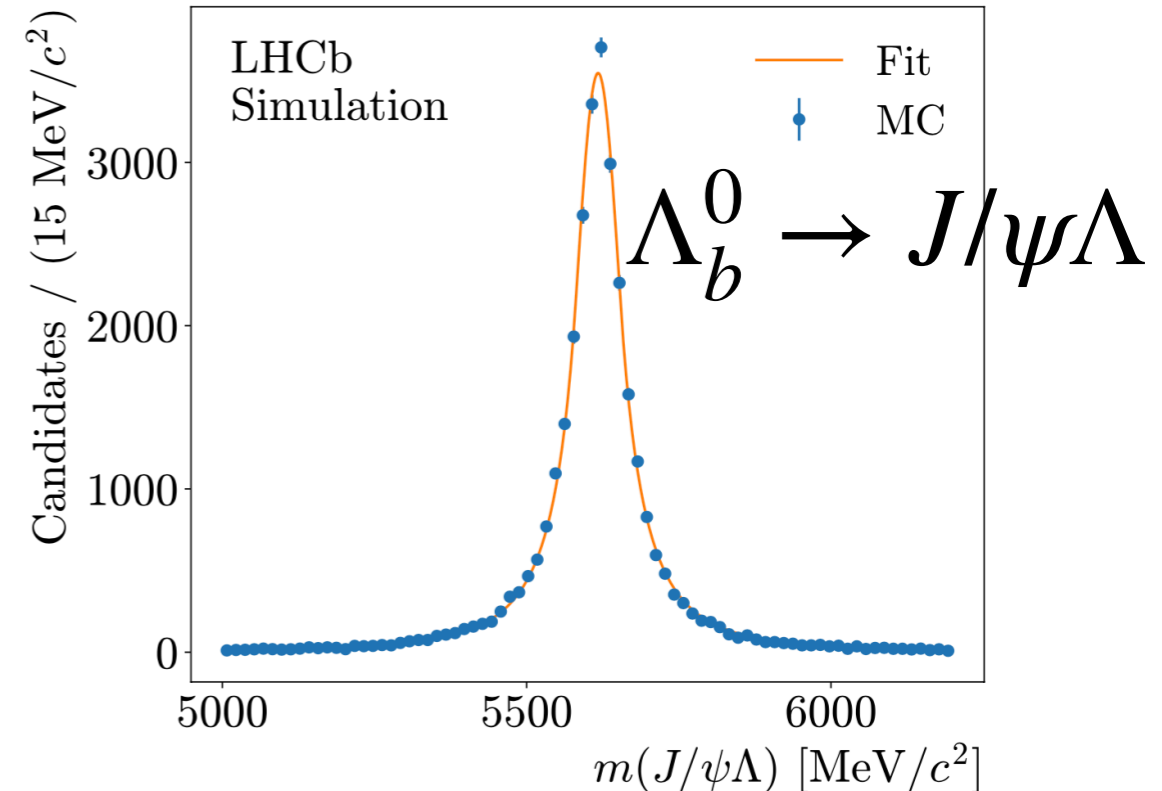
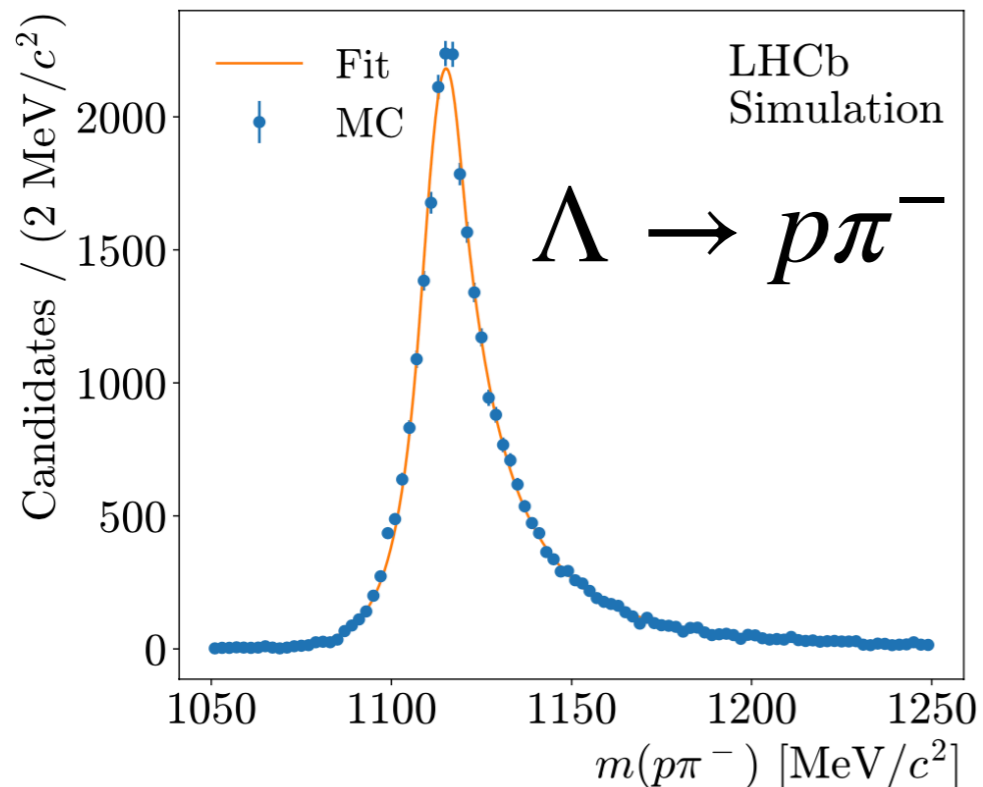

$\Lambda_b^0 \rightarrow J/\psi\Lambda$ reconstruction on Run 2 data

- ▶ Reconstruction of $\Lambda_b^0 \rightarrow J/\psi(\mu^+\mu^-)\Lambda(p\pi^-)$ with Λ decay vertex $z \in [6.0-7.6]\text{m}$ ✓
- ▶ No RICH2 info in Run2 for T tracks, T track fit and vertexing still to be optimised

LHCb-DP-2022-001
in review

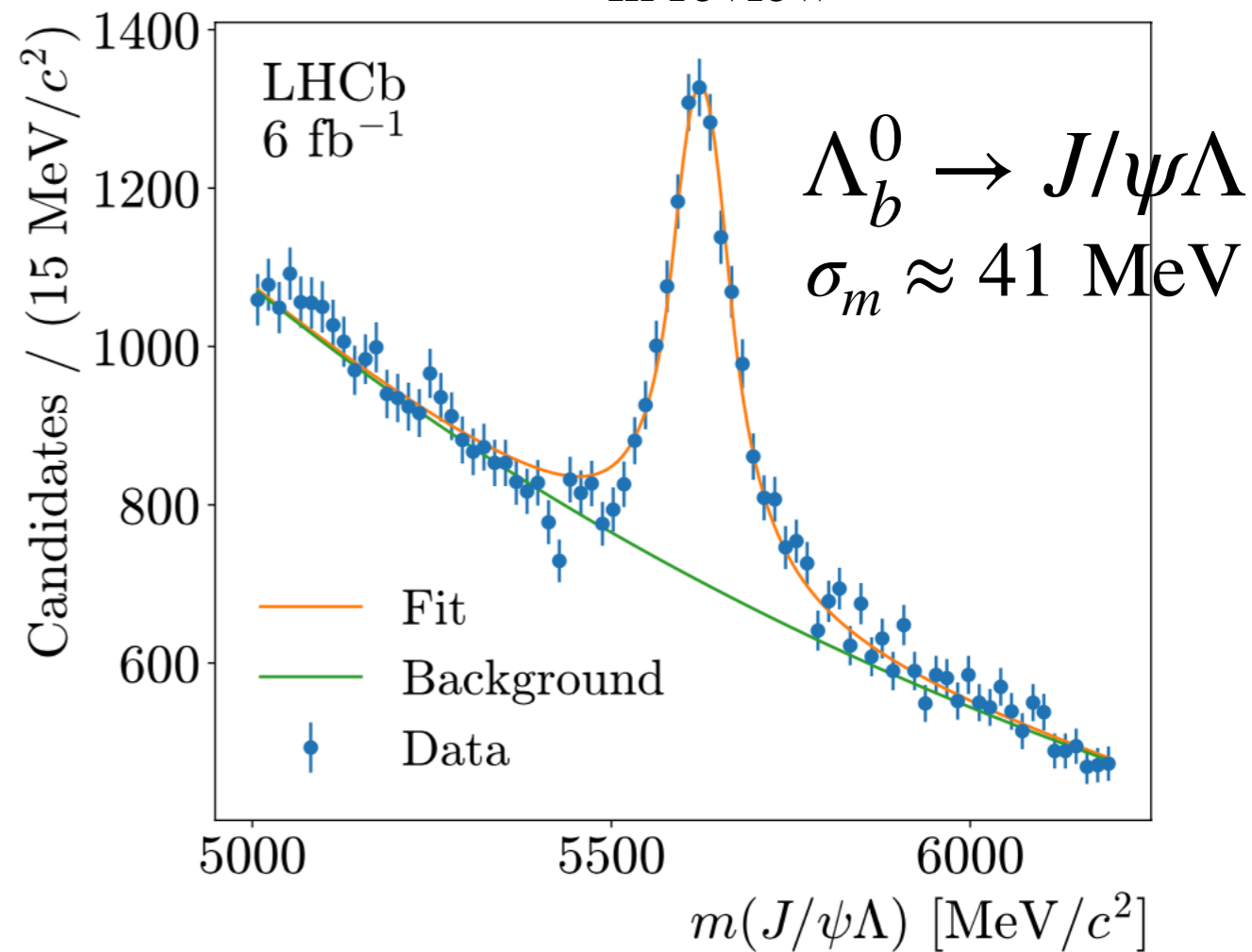
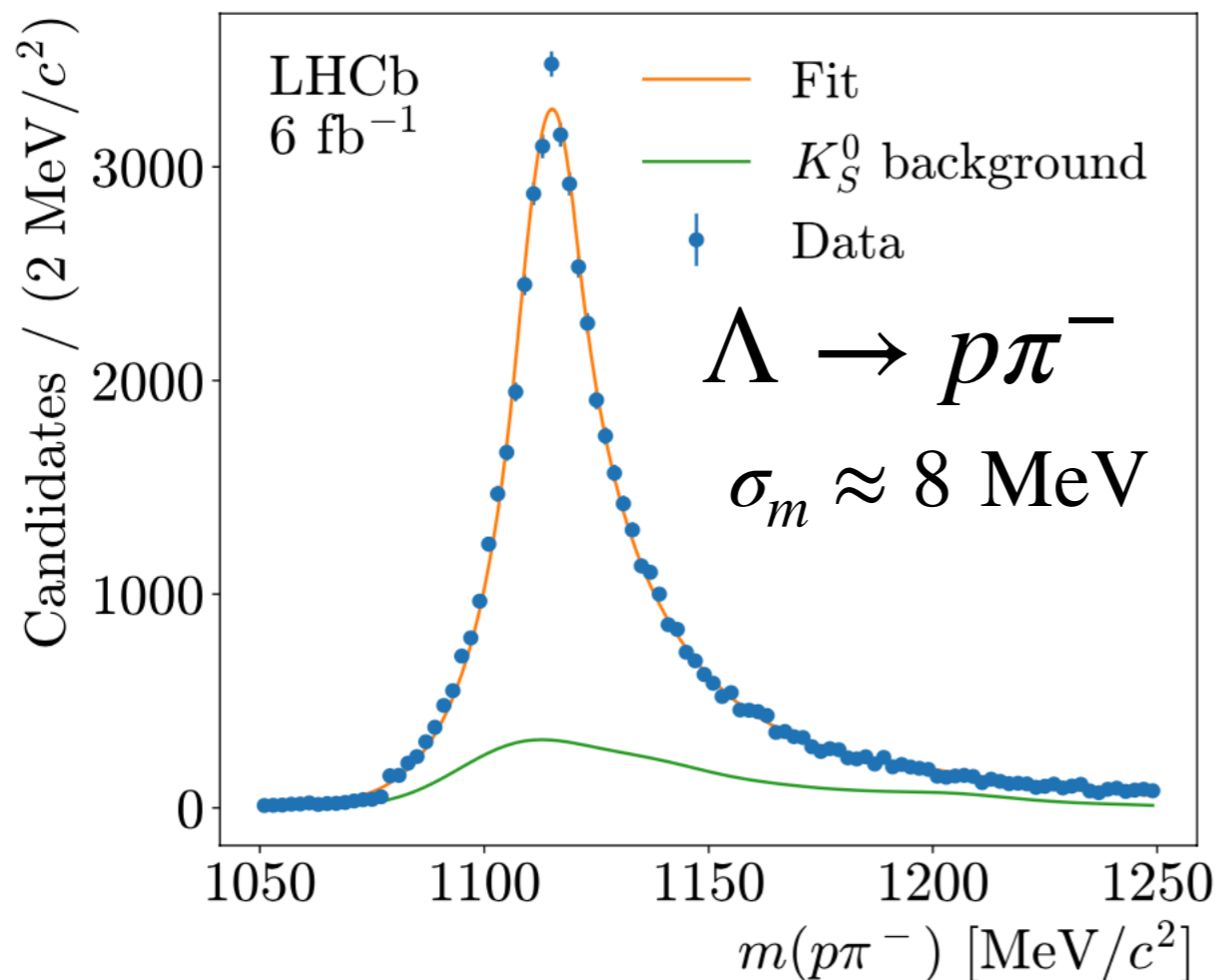

$B^0 \rightarrow J/\psi K_S^0$ reconstruction on Run 2 data

- ▶ Reconstruction of $B^0 \rightarrow J/\psi(\mu^+\mu^-)K_S^0(\pi^+\pi^-)$ with K_S^0 decay vertex $z \in [6.0-7.6]\text{m}$ ✓
- ▶ Useful **control sample**

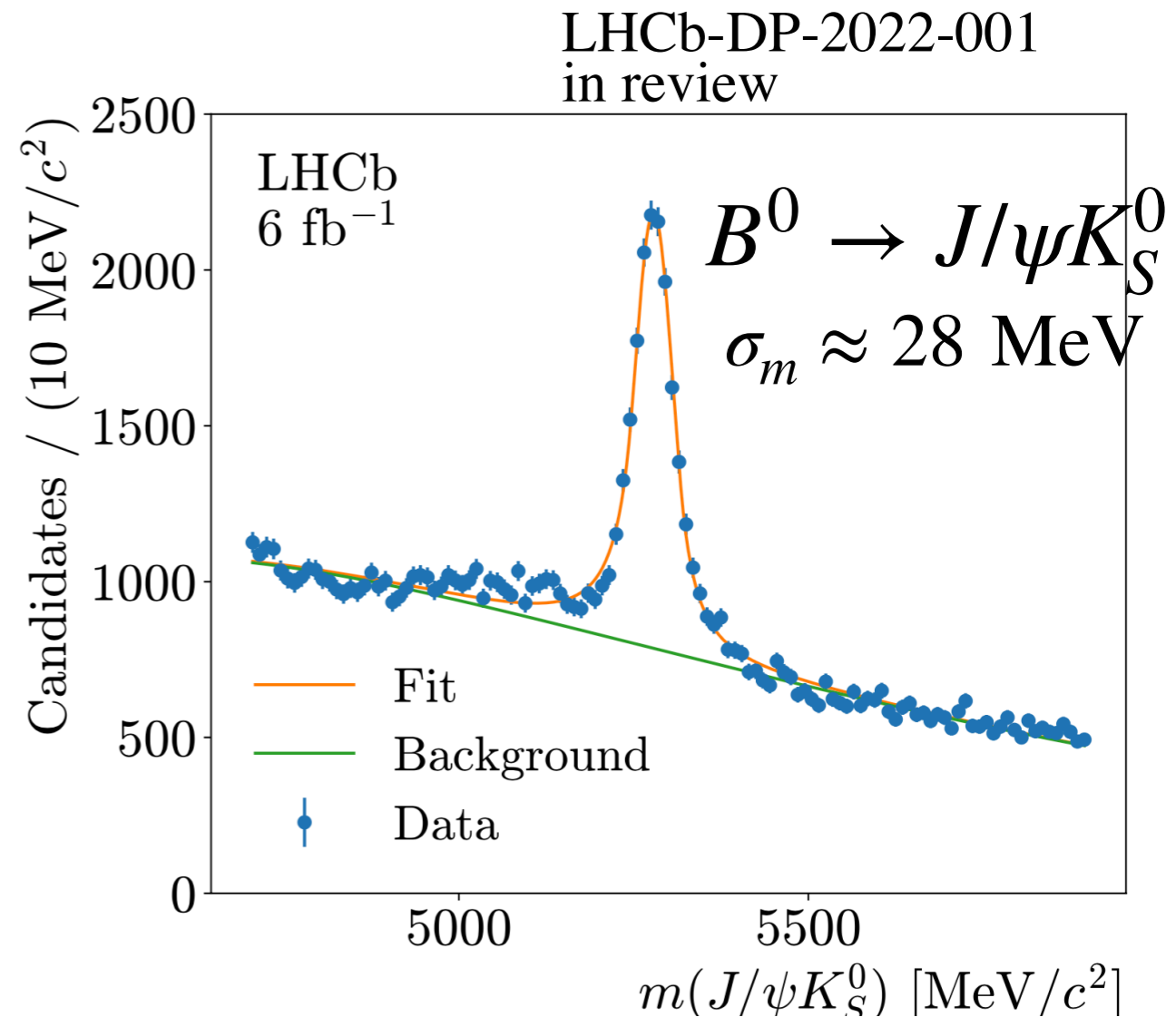
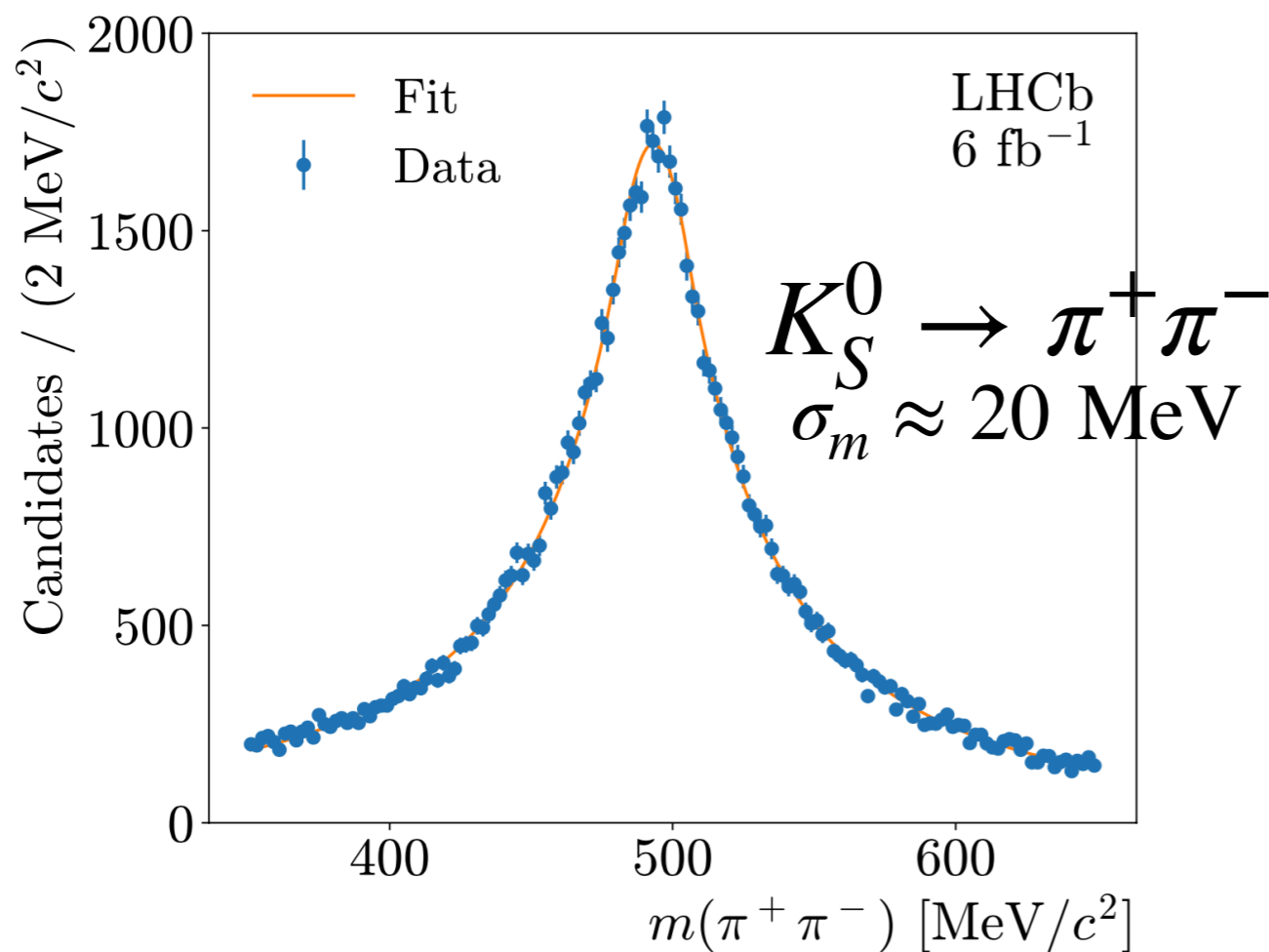

Λ baryon polarisation

- ▶ Λ polarisation close to **maximal** in $\Lambda_b^0 \rightarrow J/\psi \Lambda$ decays, JHEP 2020, 110 (2020)
- ▶ Measurements of Λ polarisation in progress for $\Xi_c^0 \rightarrow \Lambda K^- \pi^+$, $\Lambda_c^+ \rightarrow \Lambda \pi^+ \pi^- \pi^+$, $\Xi_c^0 \rightarrow \Xi^- (\Lambda \pi^-) \pi^+$ decays using **Run2 data**
- ▶ Polarisation is significantly higher for Λ generated in 2-body **weak decays** wrt multi-body decays

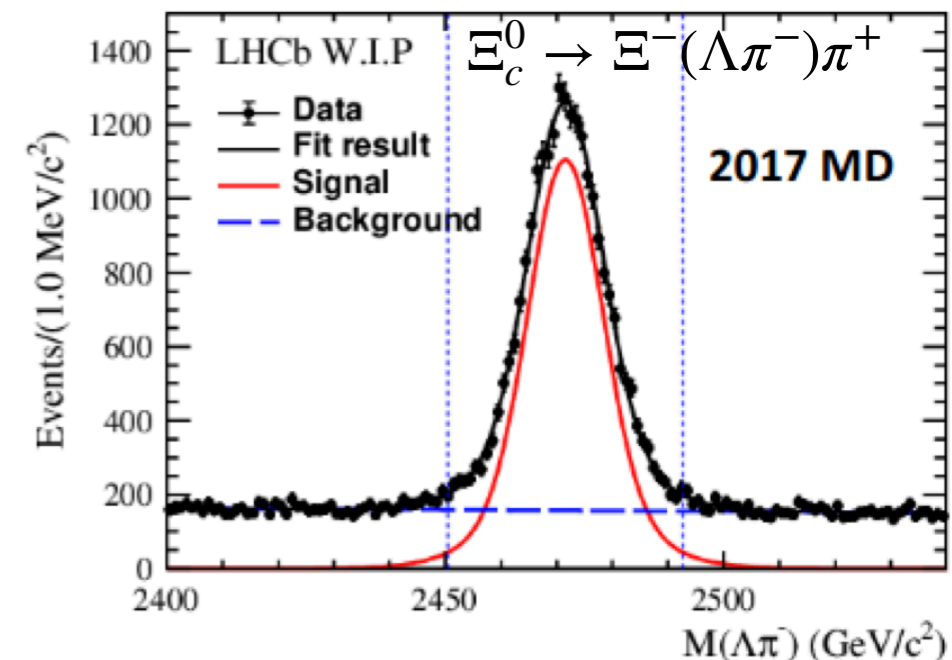
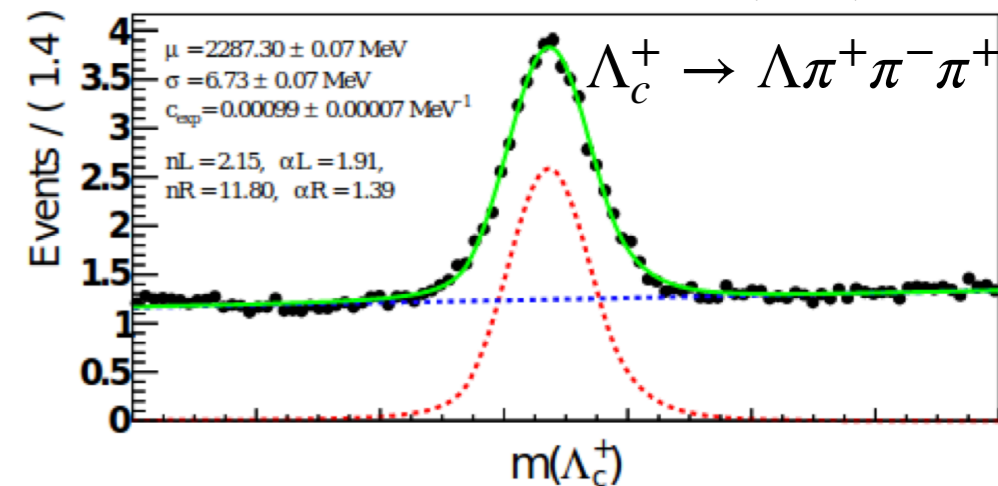
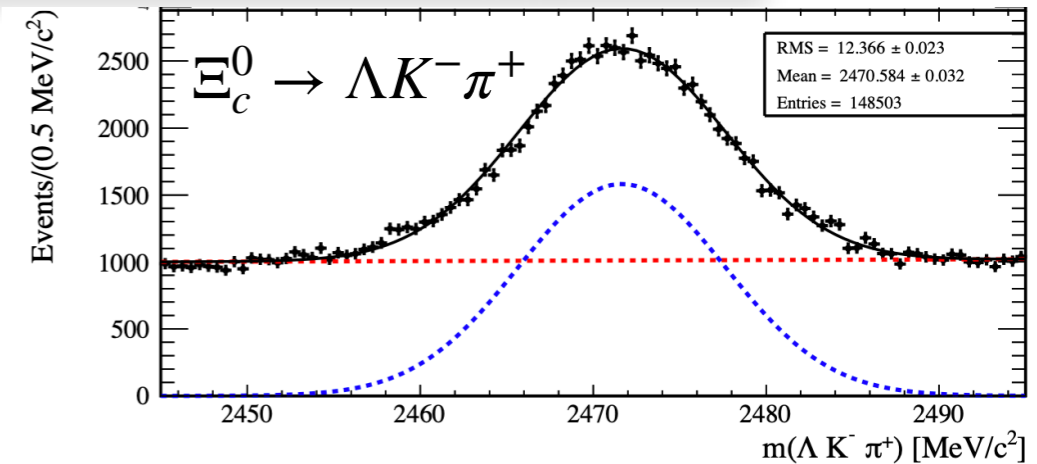

Status and plans for Run3

- ▶ Reconstructed Λ and K_S^0 decays after the magnet using Run2 data. Also opportunity to extend BSM **LLP searches** in LHCb. LHCb-DP-2022-001
- ▶ Improve reconstruction based on T tracks
 - track fit, vertexing, use PID info
 - preparing trigger lines for Run3, exploit the new flexible software trigger, improved HybridSeeding
- ▶ Unique opportunity at LHCb to perform Λ EDM/MDM **measurement** using Run1+Run2 (started) and Run3 data

S. Aiola et al., Computer Physics Communications, 2020, 107713

CPT test $\approx 10^{-3}$ via $\Lambda/\bar{\Lambda}$ MDM

EDM limit $\approx 10^{-18}$ e cm with 50 fb⁻¹

Sensitivity on MDM/EDM

- ▶ Spin rotation after LHCb magnet (B field) for $\mathbf{s}_0 = s_0 \hat{z}$

$$\mathbf{s} = \begin{cases} s_x = -s_0 \sin \Phi \\ s_y = -s_0 \frac{d\beta}{g} \sin \Phi \\ s_z = s_0 \cos \Phi \end{cases} \quad \Phi \approx \frac{g\mu_B BL}{\beta \hbar c} \approx \frac{\pi}{4} \quad BL \approx 4 \text{ T m}$$

Spin analyser in Λ rest frame

$$\frac{dN}{d\Omega'} \propto 1 + \alpha \mathbf{s} \cdot \hat{\mathbf{k}},$$

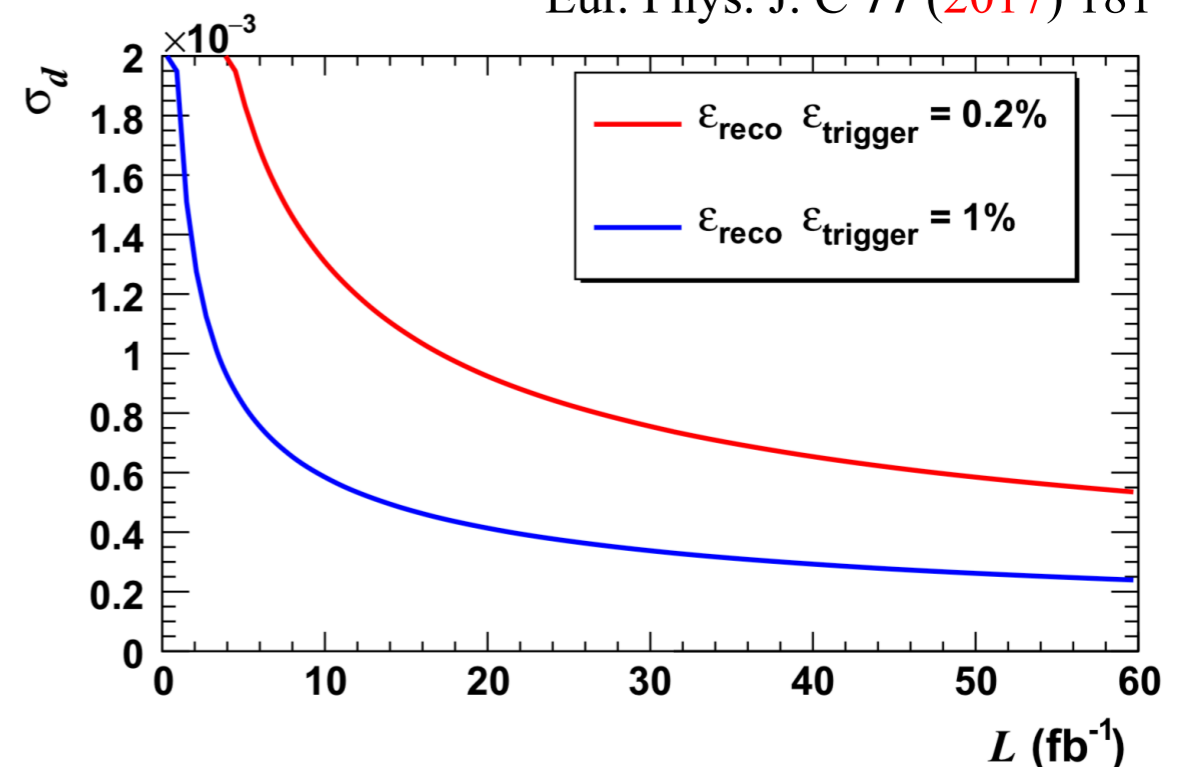
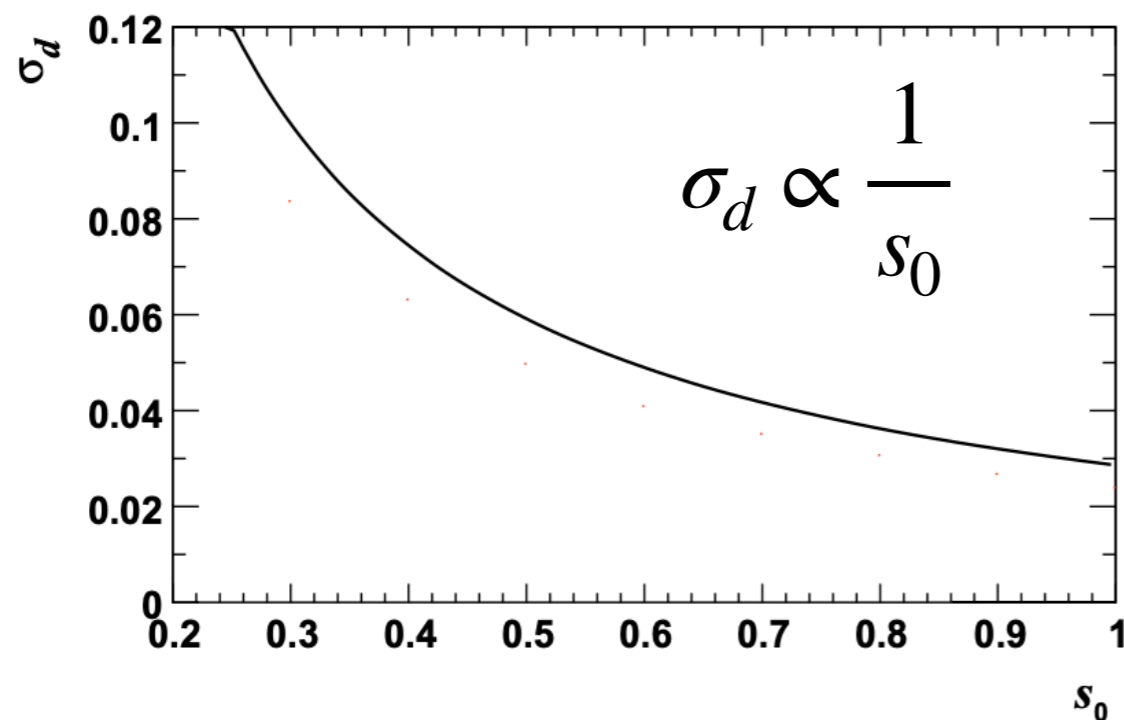

Eur. Phys. J. C **77** (2017) 181

Proposed experimental method for charm baryons at LHC: Λ_c^+ , Ξ_c^+ $\tau \approx 10^{-13}$ s

V. G. Baryshevsky, Phys.Lett.B 757 (2016) 426

L. Burmistrov et al, CERN-SPSC-2016-030, SPSC-EOI-012 (2016)

F. J. Botella et al., Eur.Phys.J.C 77 (2017) 181

A. S. Fomin et al., JHEP 1708 (2017) 120

E. Bagli et al., Eur.Phys.J.C 77 (2017) 828

A. S. Fomin et al., Eur.Phys.J.C 80(2020) 358

S. Aiola et al., Phys.Rev.D 103 (2021) 072003

LHCb-INT-2017-011

Channeling in bent crystals



Courtesy of Biryukov, Chesnokov, Kotov, “Crystal channeling and its applications at high-energy accelerators” (Springer)

Channeling in bent crystals

- ▶ Potential well between crystal planes
 $E \approx 1 \text{ GV/cm}$

- ▶ Positive charge particle with momentum parallel to crystal plane (within **few μrad**) can be trapped

- ▶ Well understood phenomenon (Lindhard 1965)

- ▶ **Bent crystals** used to:

- **steer** high-energy particle beams, very high effective magnetic field $B \approx 500 \text{ T}$
- induce **spin precession**

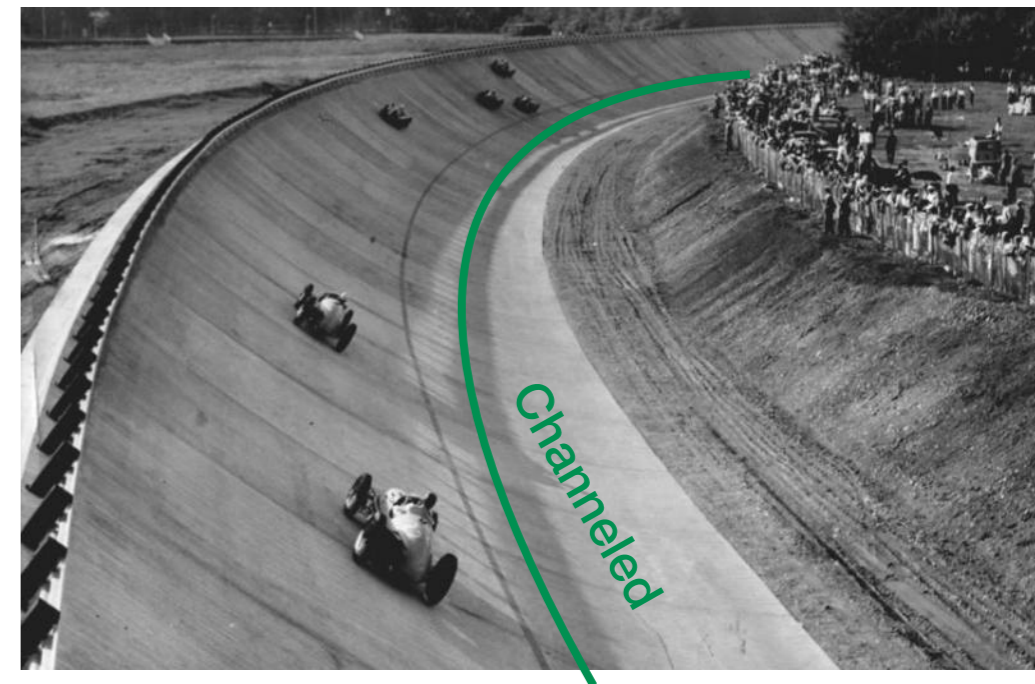
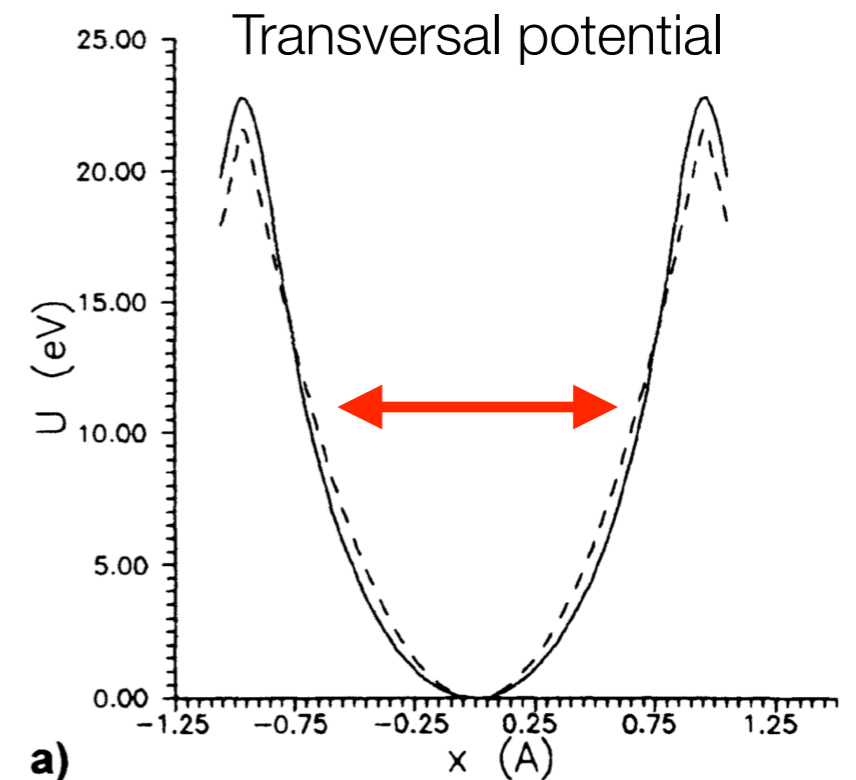

Spin precession in bent crystals

- ▶ Firstly predicted by **Baryshevsky** (1979)

V.G. Baryshevsky, Pis'ma Zh. Tekh. Fiz. 5 (1979) 182.

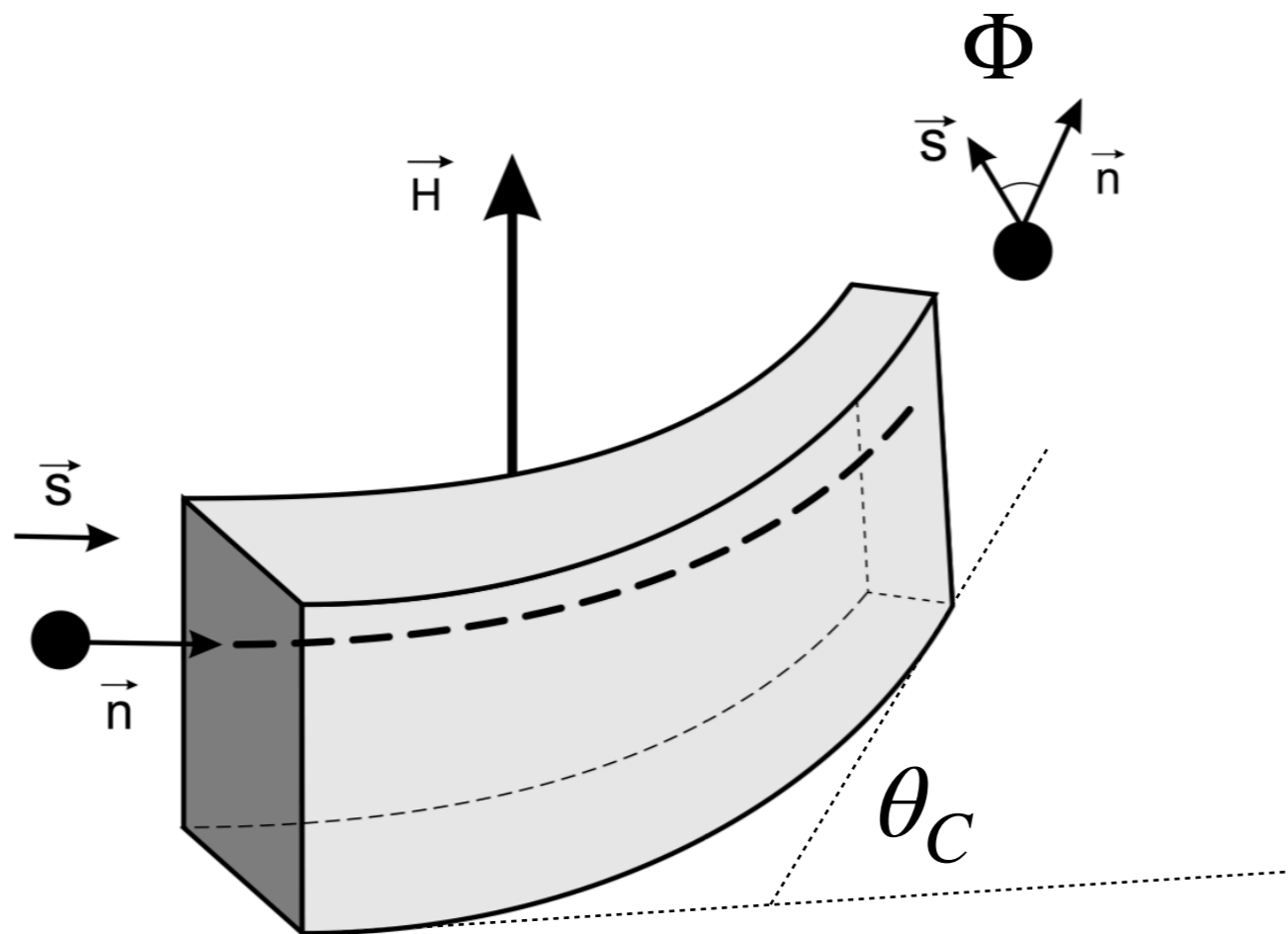

Fig. 1. Spin rotation in a bent crystal.

- ▶ Determine particle gyromagnetic factor from BMT equation

V.L. Lyuboshits, Sov. J. Nucl. Phys. 31 (1980) 509.

$$\Phi = \frac{g - 2}{2} \gamma \theta_C$$

Φ = spin rotation angle

θ_C = crystal bending angle

g = gyromagnetic factor

γ = Lorentz boost

- ▶ Experimental proof by E761 Fermilab experiment with Σ^+ hyperon

D. Chen et al., Phys. Rev. Lett. 69 (1992) 3286

Λ_c^+ , Ξ_c^+ spin precession in bent crystals at LHC

- Spin precession angle $\Phi \simeq \frac{g-2}{2}\gamma\theta_C$ for baryons with **large boost** $\gamma \approx 500$ and bending angle $\theta_C \approx 15$ mrad

$$\frac{d\mathbf{S}}{d\tau} = \boldsymbol{\mu} \times \mathbf{B}^* + \boldsymbol{\delta} \times \mathbf{E}^*$$

$\mathbf{E}^* \perp \mathbf{B}^*$ in particle rest frame

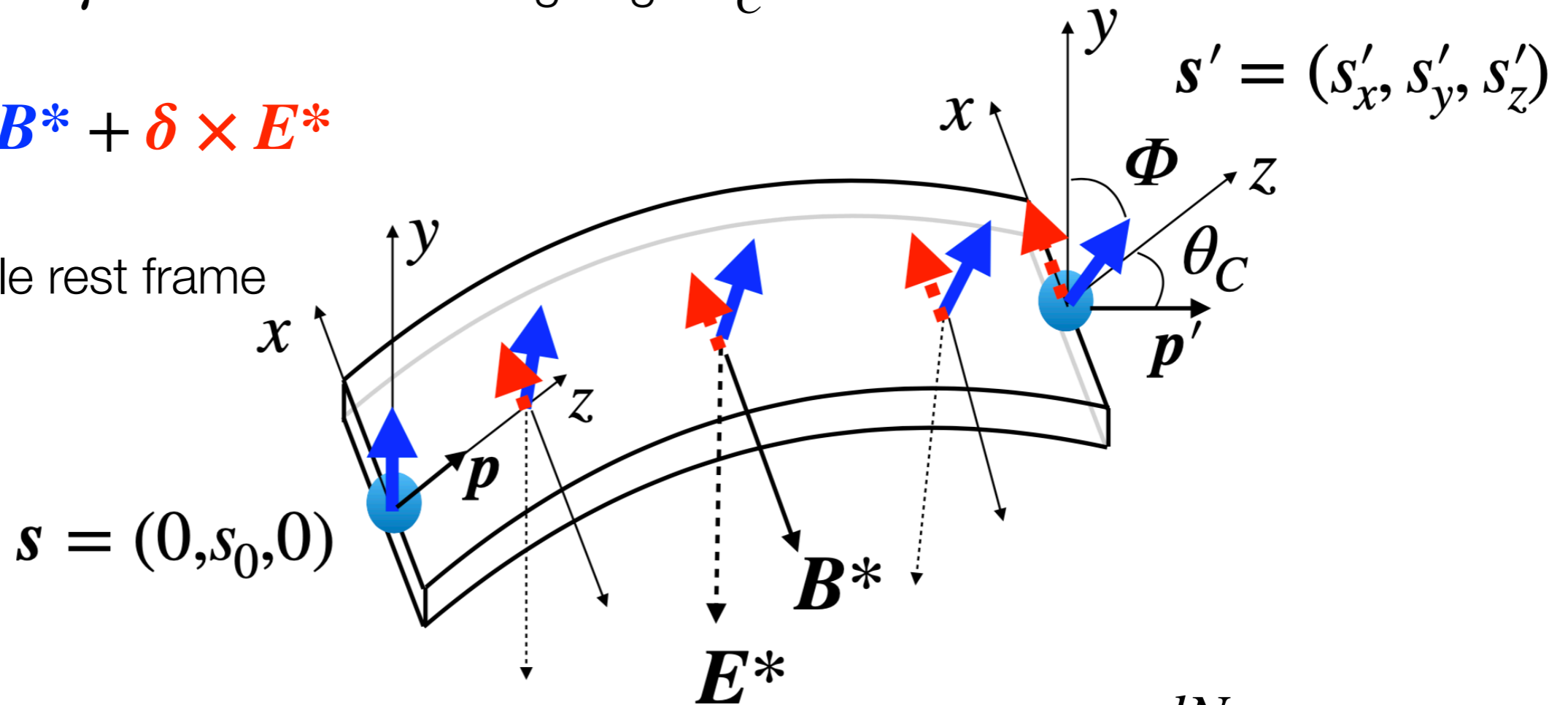

- Sensitivity to **MDM** and **EDM** via spin-polarisation analyser $\frac{dN}{d\Omega'} \propto 1 + \alpha \mathbf{s}' \cdot \hat{\mathbf{k}}$

$$\Phi \approx \frac{g-2}{2}\gamma\theta_C$$

$$s'_x \approx s_0 \frac{d}{g-2} [\cos(\Phi) - 1]$$

EPJC (2017) 77:181

Novel fixed-target experiment at LHC for charm baryons

- ▶ EDM/MDM from spin precession of channeled baryons in **bent crystals**

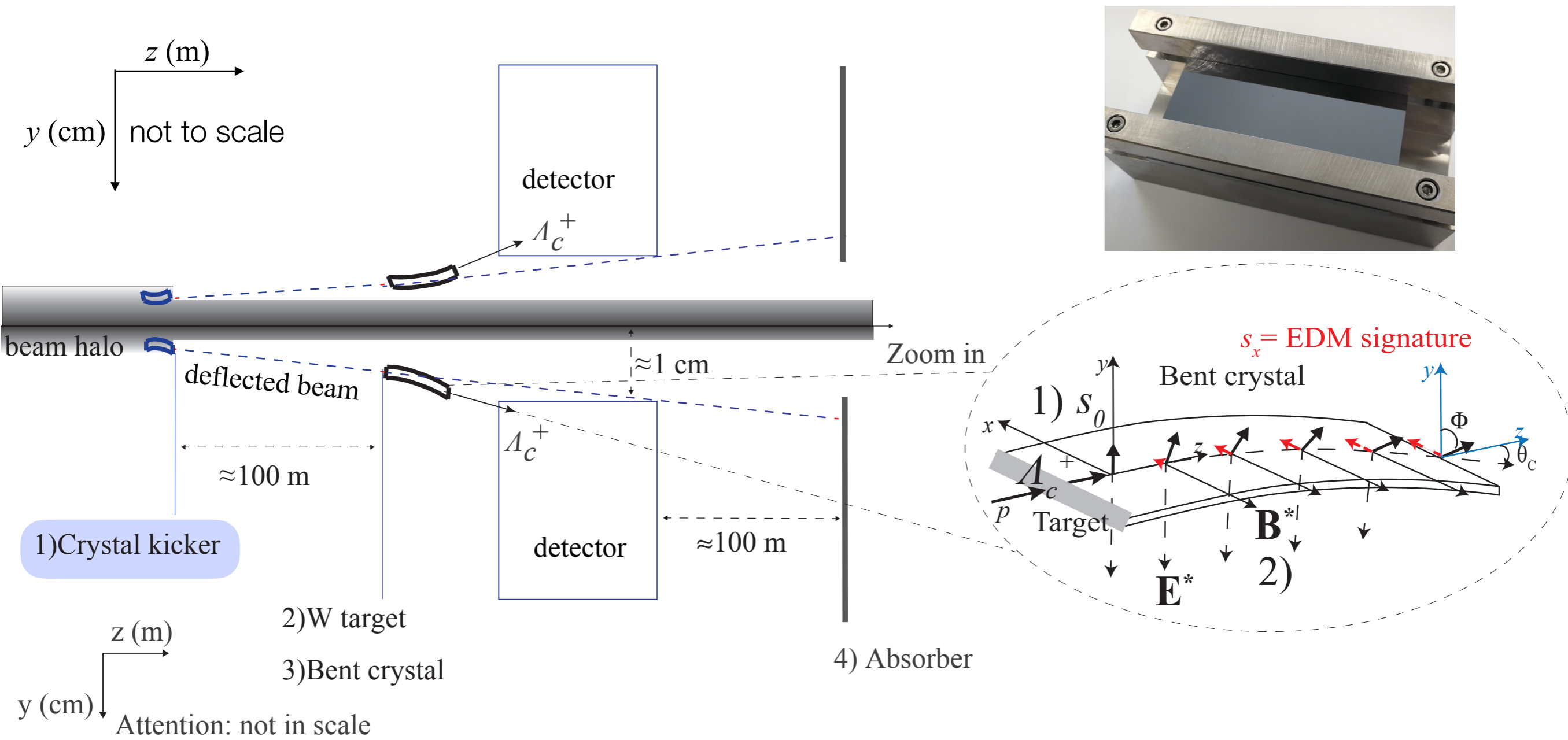

p extraction

Novel fixed-target experiment at LHC for charm baryons

- ▶ EDM/MDM from spin precession of channeled baryons in **bent crystals**

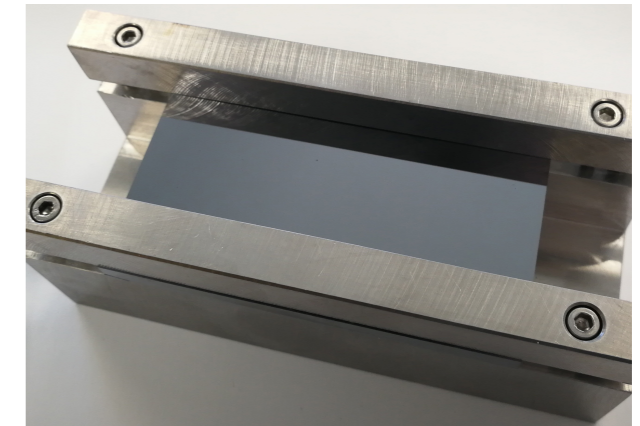
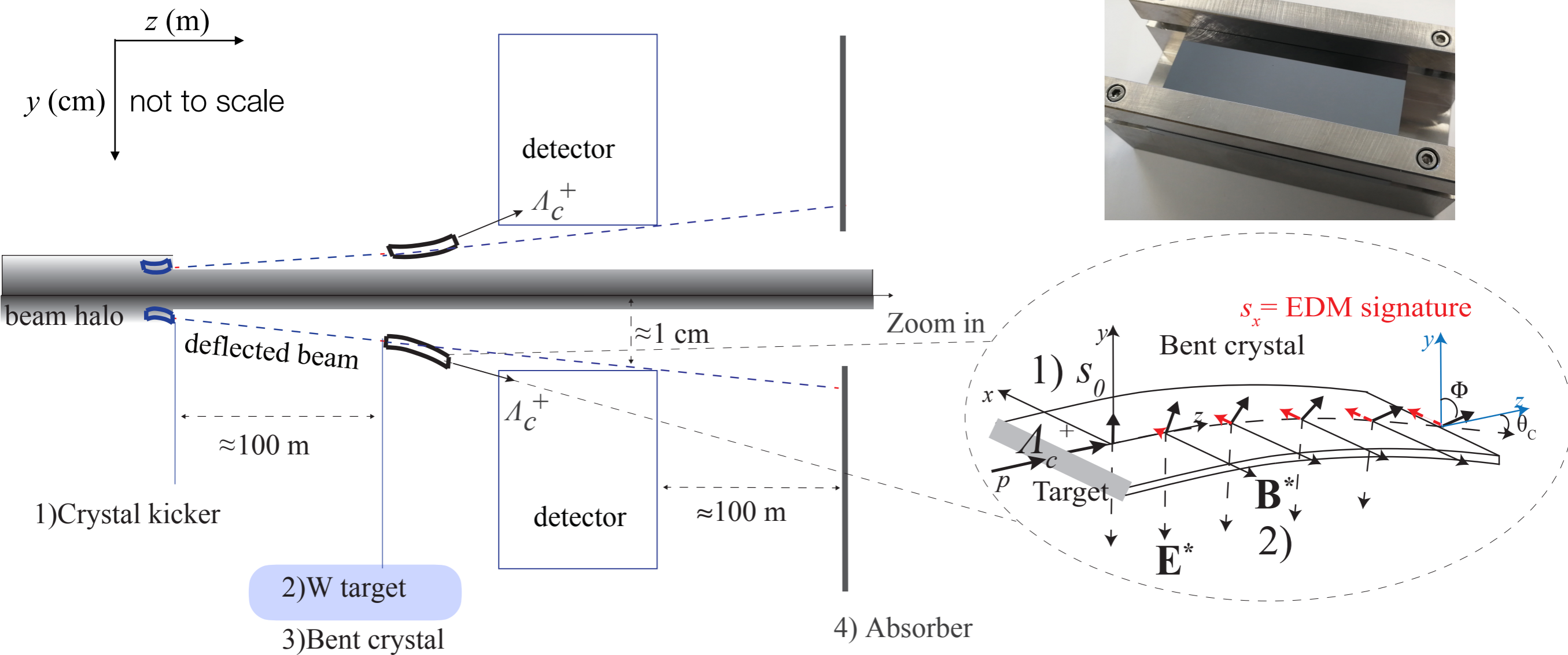

p extraction Λ_c^+ polarised production

Novel fixed-target experiment at LHC for charm baryons

- ▶ EDM/MDM from spin precession of channeled baryons in **bent crystals**

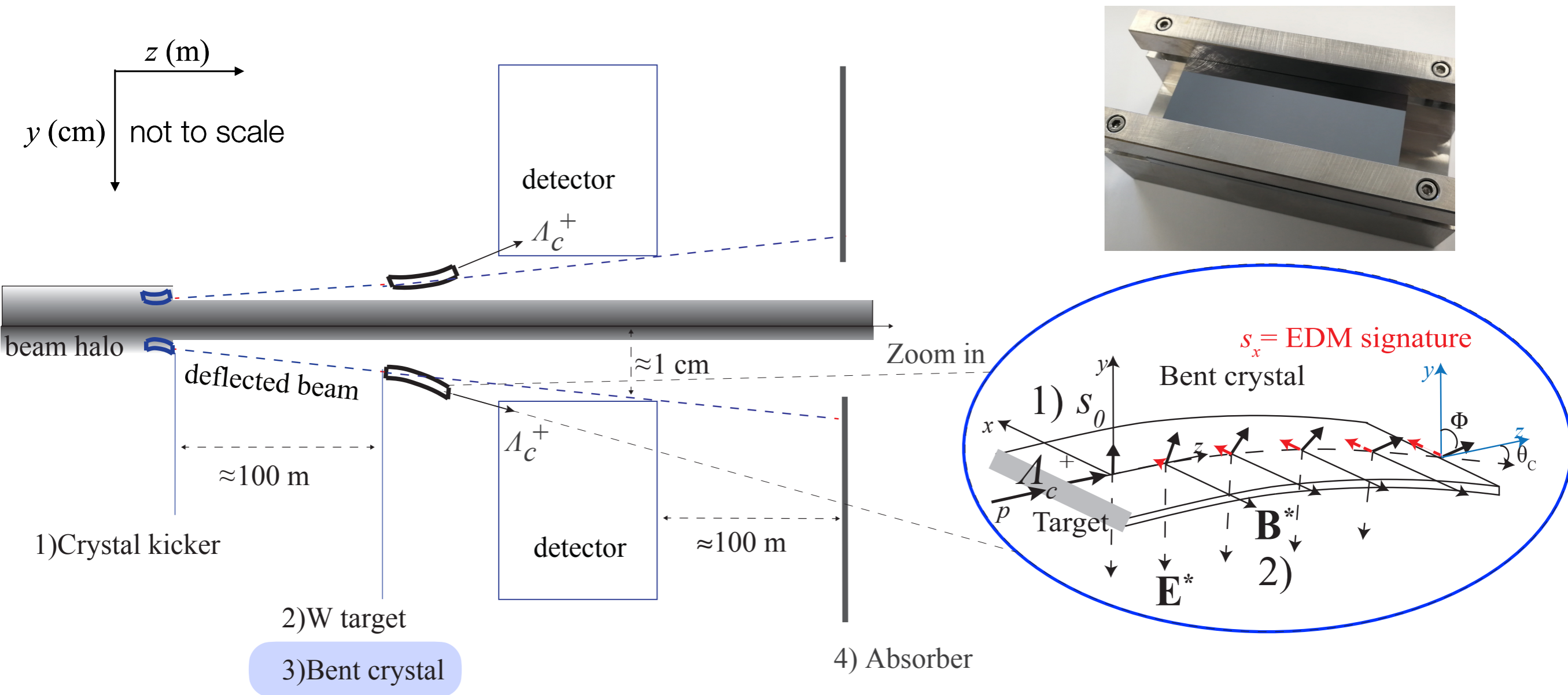

p extraction Λ_c^+ polarised production channeling spin precession

Novel fixed-target experiment at LHC for charm baryons

- ▶ EDM/MDM from spin precession of channeled baryons in **bent crystals**

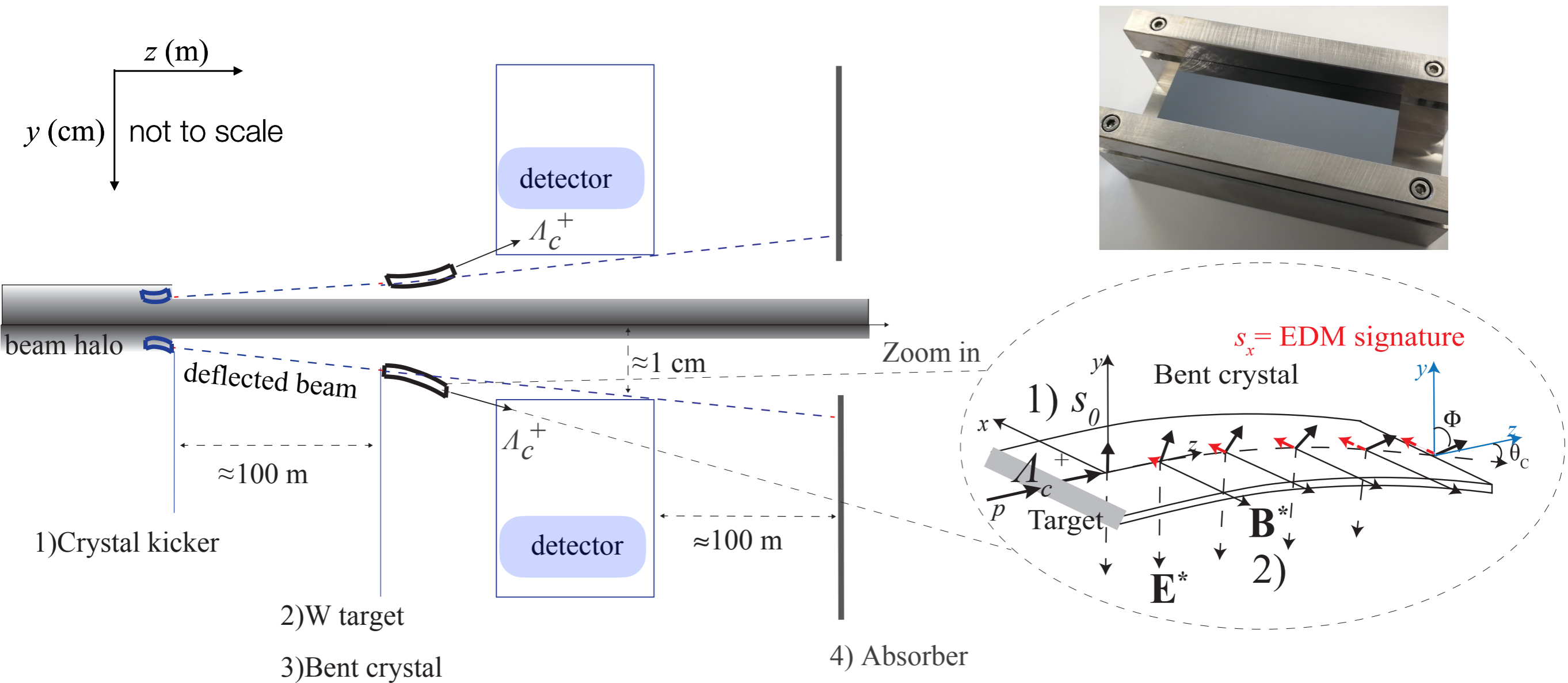

p extraction Λ_c^+ polarised production channeling spin precession event reconstruction

Sensitivity on MDM/EDM

- ▶ S1 configuration: **LHCb detector, Ge (Si) 16 mrad, 10 cm**
- ▶ S2 configuration: **dedicated experiment, Ge 7 mrad, 7 cm**

PoT = proton on target
W target 2 cm thick

Λ_c^+ baryon

PRD 103, 072003 (2021)

Ξ_c^+ baryon

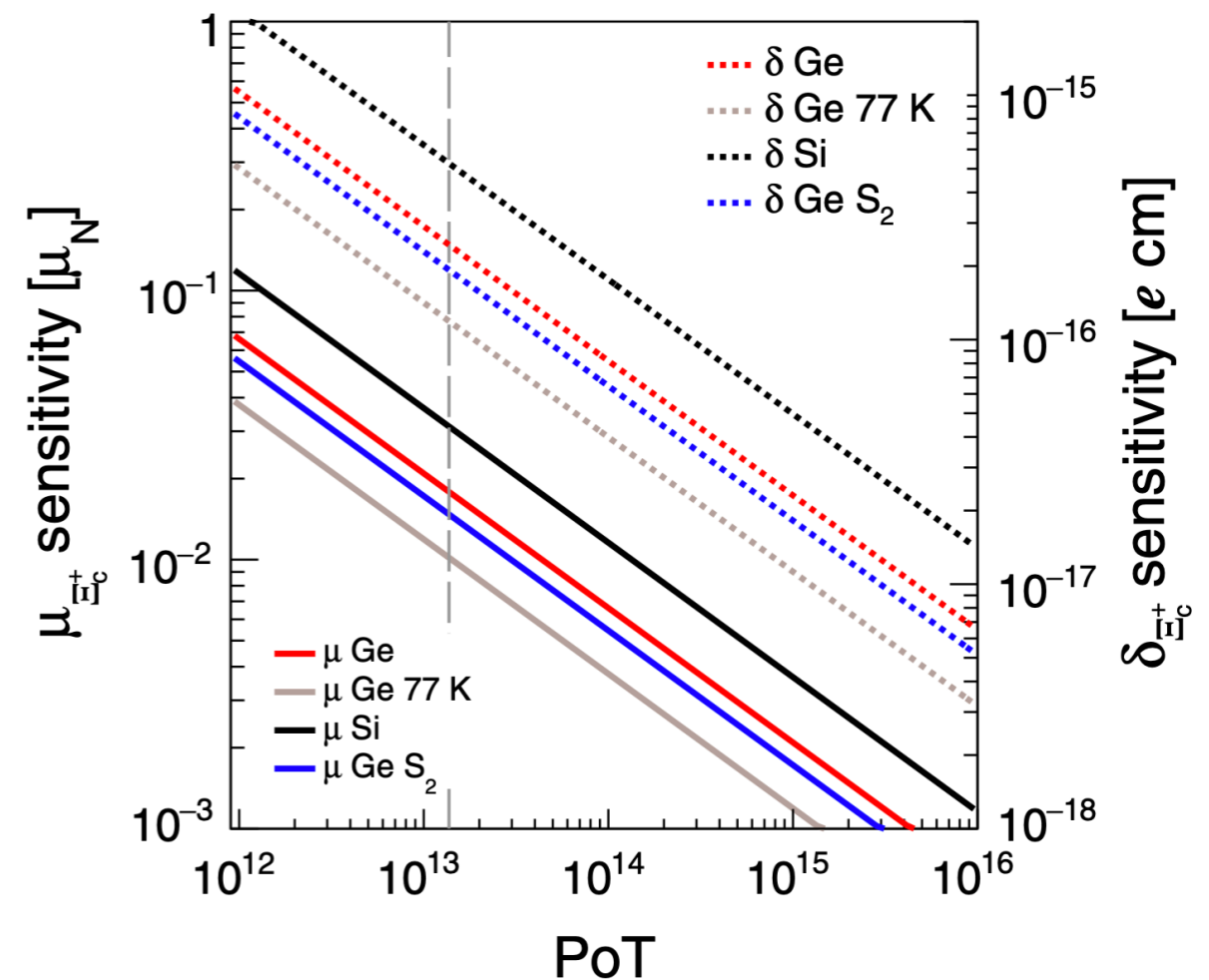
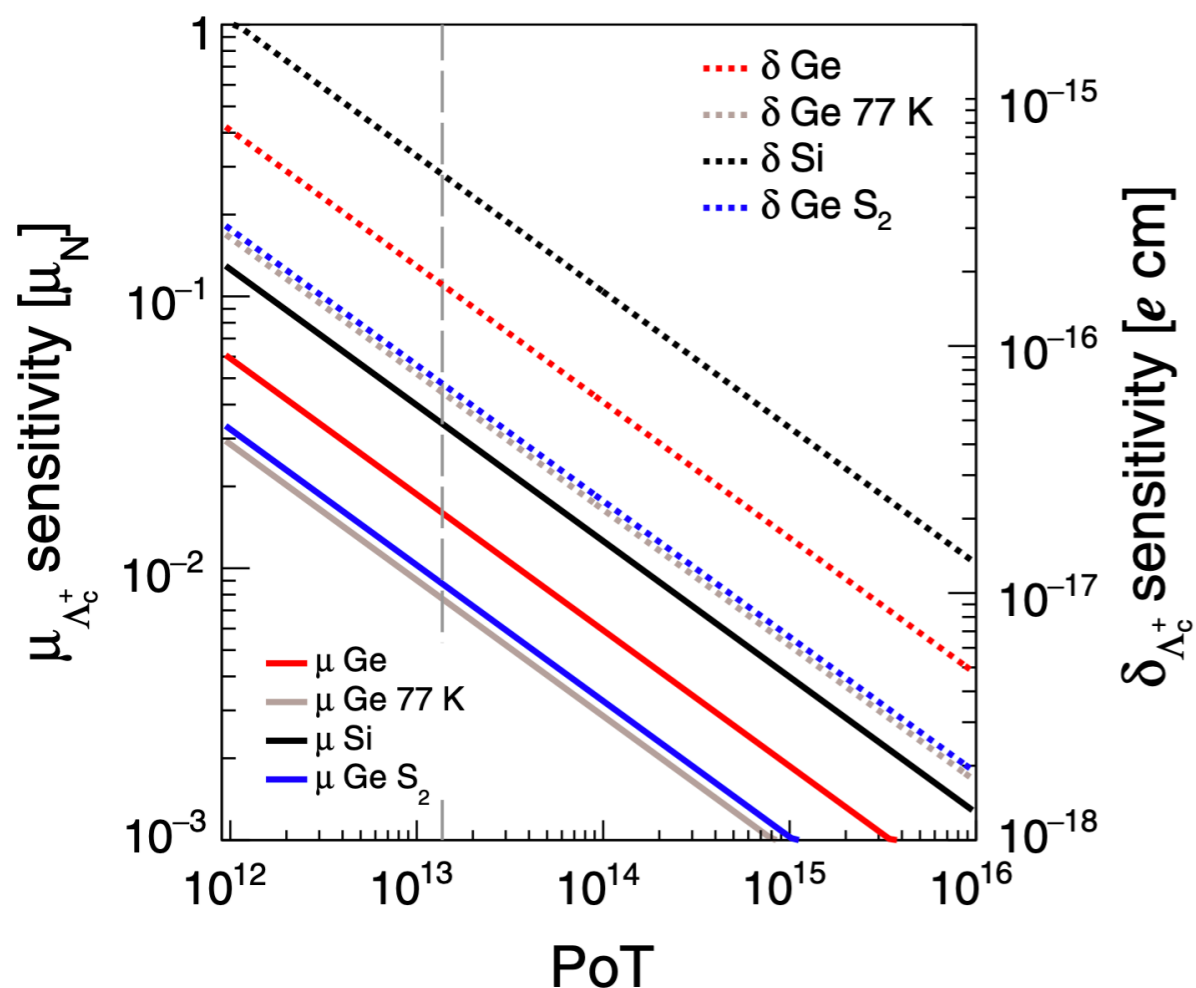

- ▶ Measurements are **statistically limited**

R&D and preparatory studies

LHC (SPS) machine studies

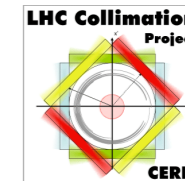

D. Mirarchi, A. S. Fomin, S. Redaelli, W. Scandale,
EPJC 80 (2020) 10, 929

W. Scandale et al., NIM A 1015 (2021) 165747

LHC machine layout simulations

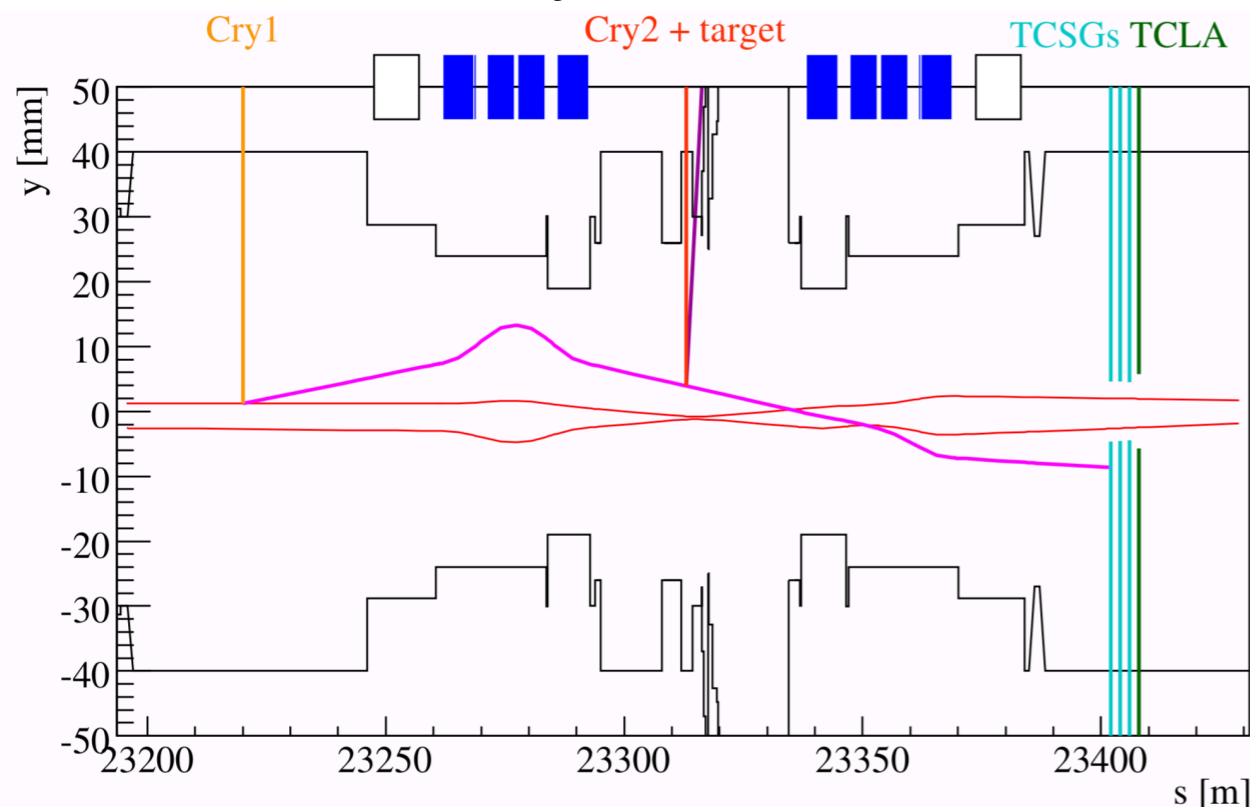

Experimental results at SPS

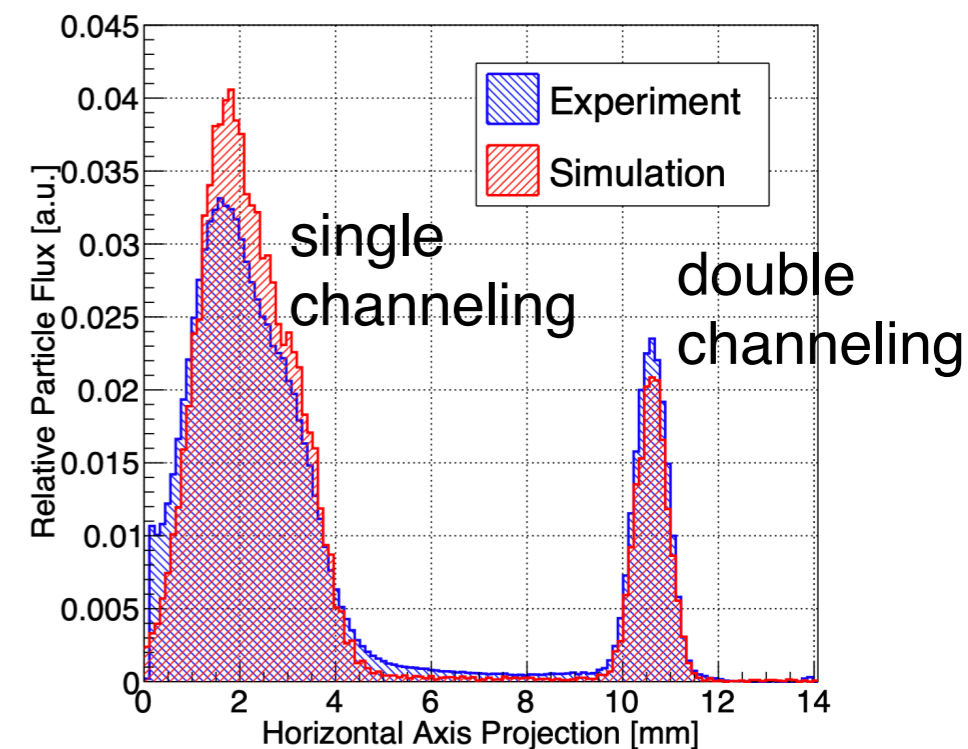

W. Scandale et al., PLB 758 (2016) 129–133

- **Channeling** of 6.5 TeV at **LHC** already **demonstrated** by UA9
- **Viable layout**: 10^6 p/s on target close to LHCb. Possibility to improve performance with a dedicated experiment at LHC
- Successful **layout test** done at SPS. Test in **LHC** possibly during Run3

Simulation studies in LHCb

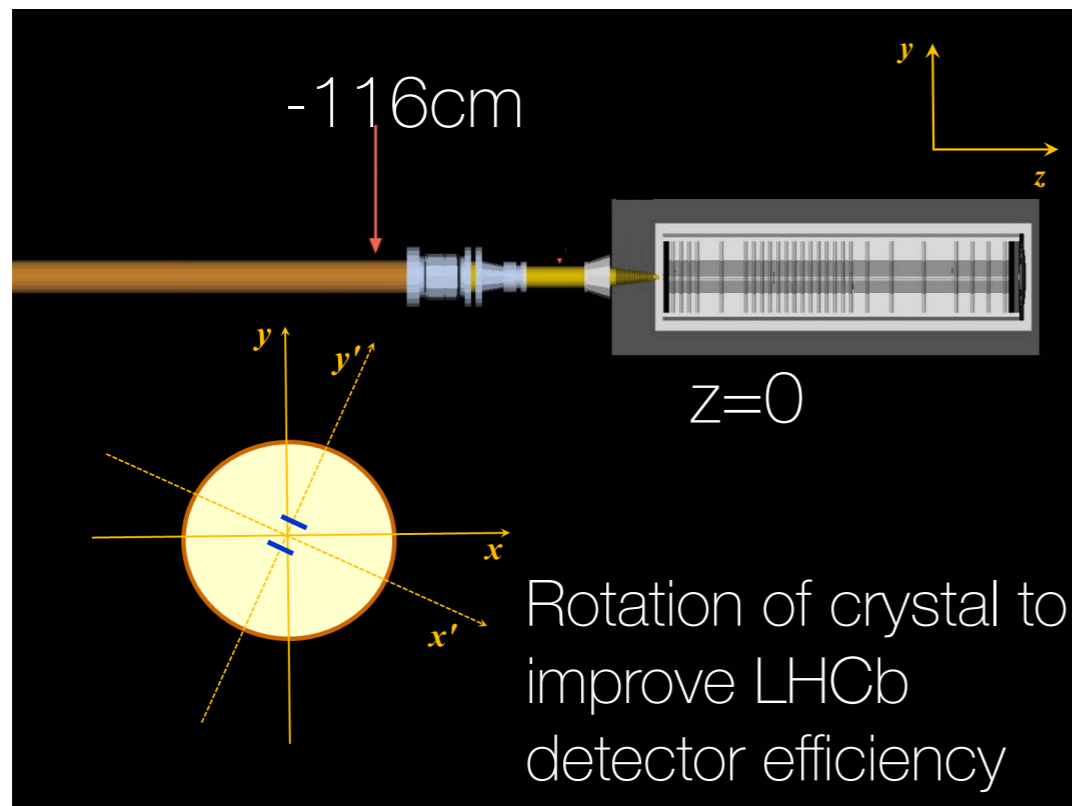

- ▶ Good performance (signal and bkg) with LHCb detector. Full **simulation** of **fixed-target setup**: W target 0.5-2.0 cm and bent crystal
- ▶ $\nu_{target} \lesssim 0.01$ with 10^6 p/s on target
- ▶ About 10^{-4} Λ_c^+ are channeled and have **high momentum** $\gtrsim 1$ TeV

Andrea Merli PhD thesis CERN-THESIS-2019-108

Good res. on production and decay vertex (7-8mm), θ_C angle ($25\mu\text{rad}$), $m(pK\pi)$ (20 MeV)

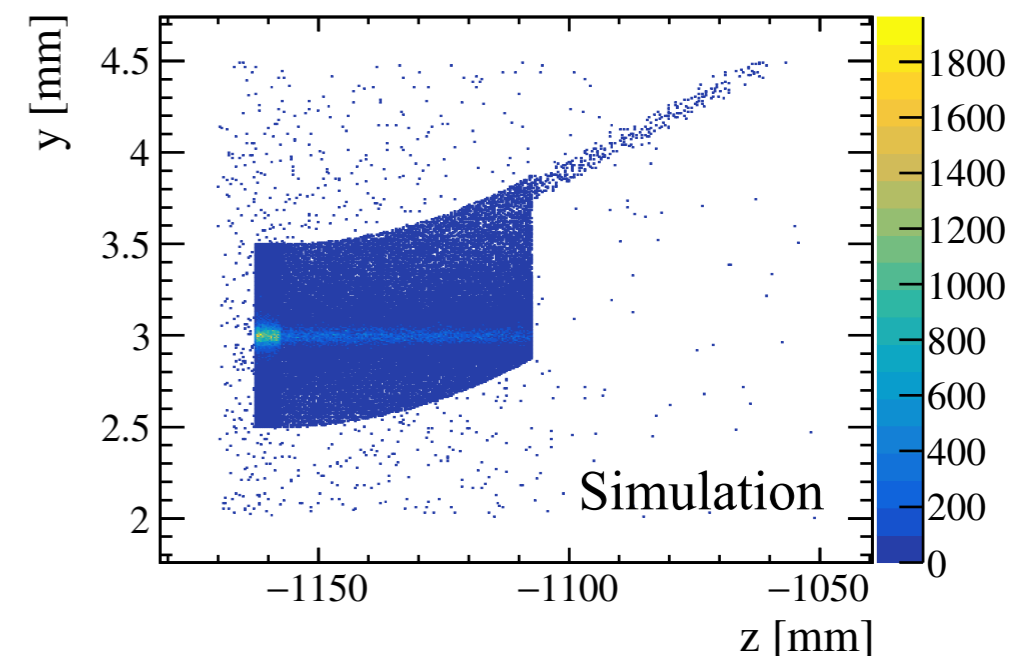
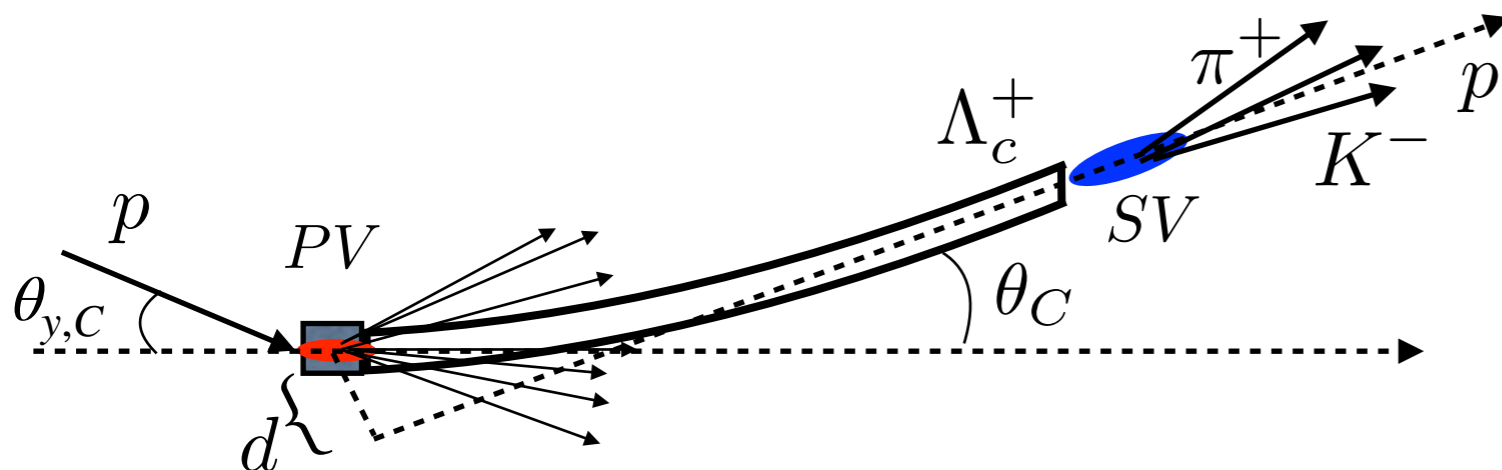

Long bent crystal prototypes

Si: 8 cm long, bent @16.0 mrad

Ge: 5 cm long, bent @14.5 mrad

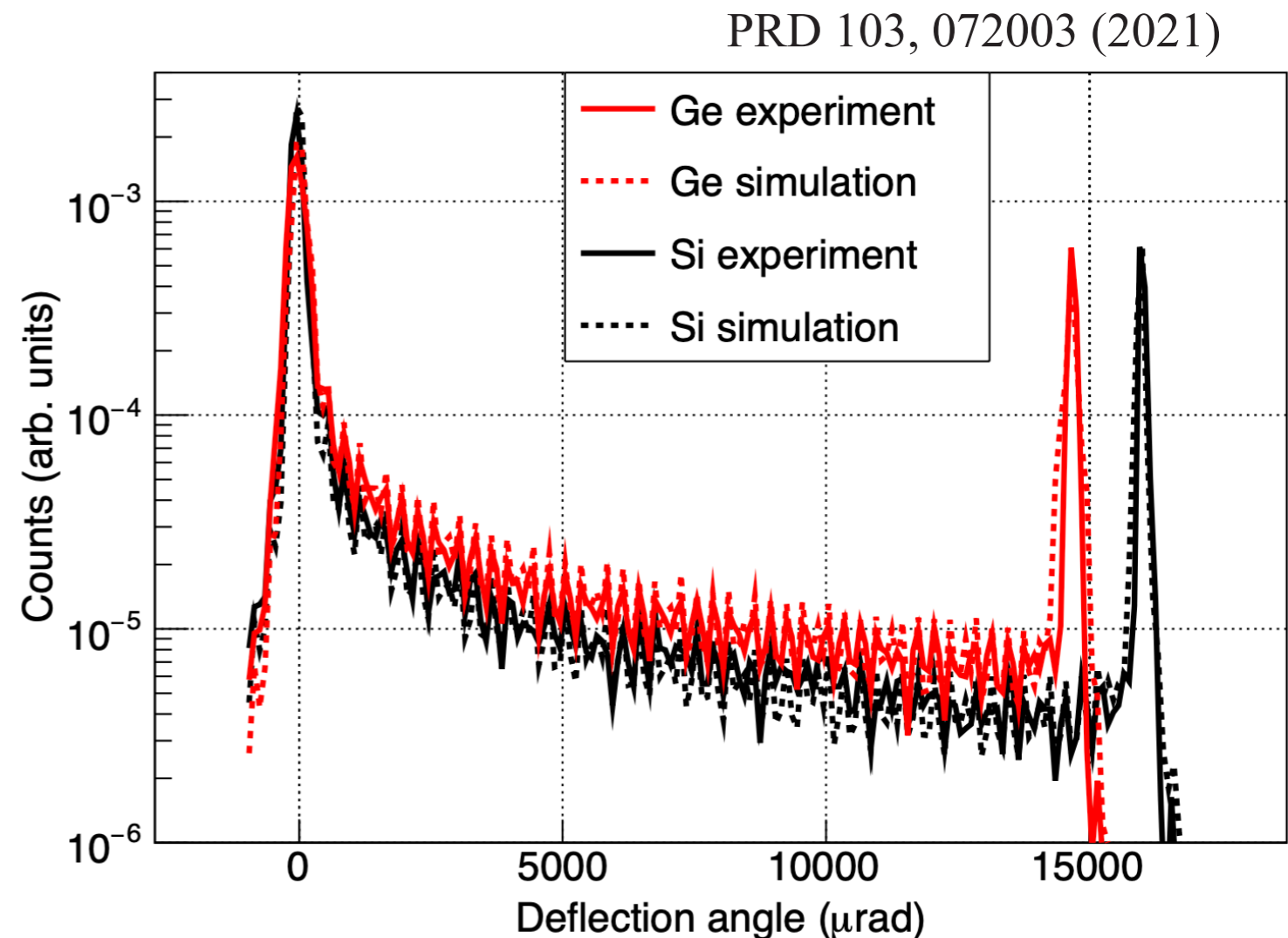
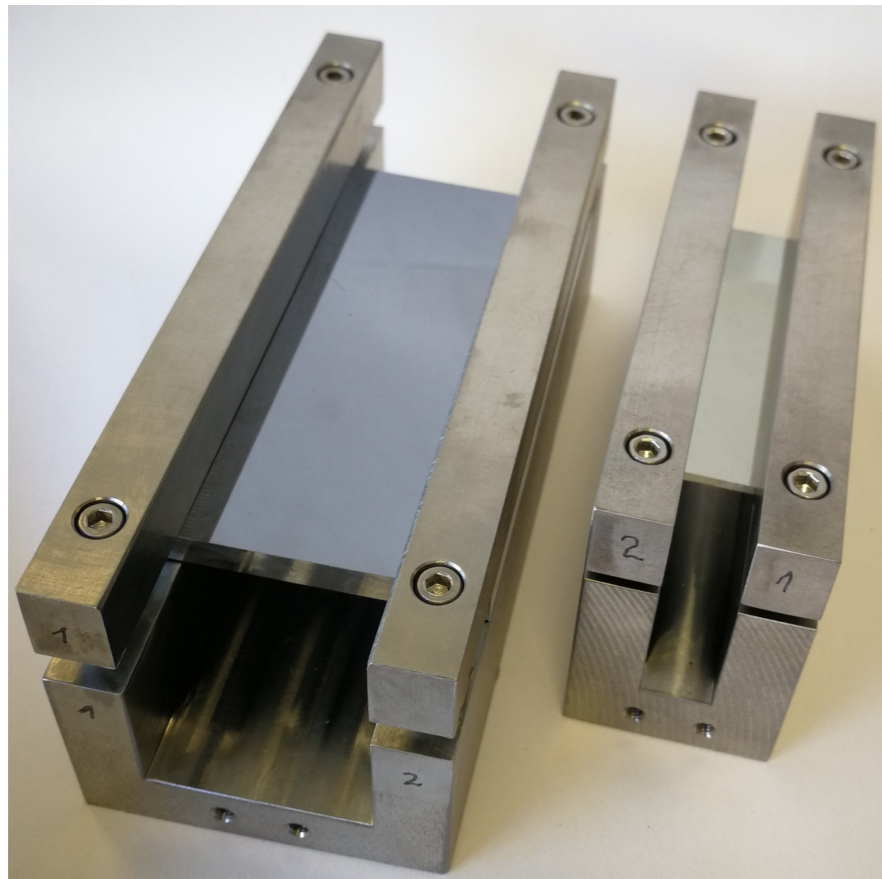

- **Si** and **Ge** long bent crystals developed at INFN-Ferrara.
Channeling efficiency $>10\%$ for 180 GeV/c pions

Long bent crystal prototypes

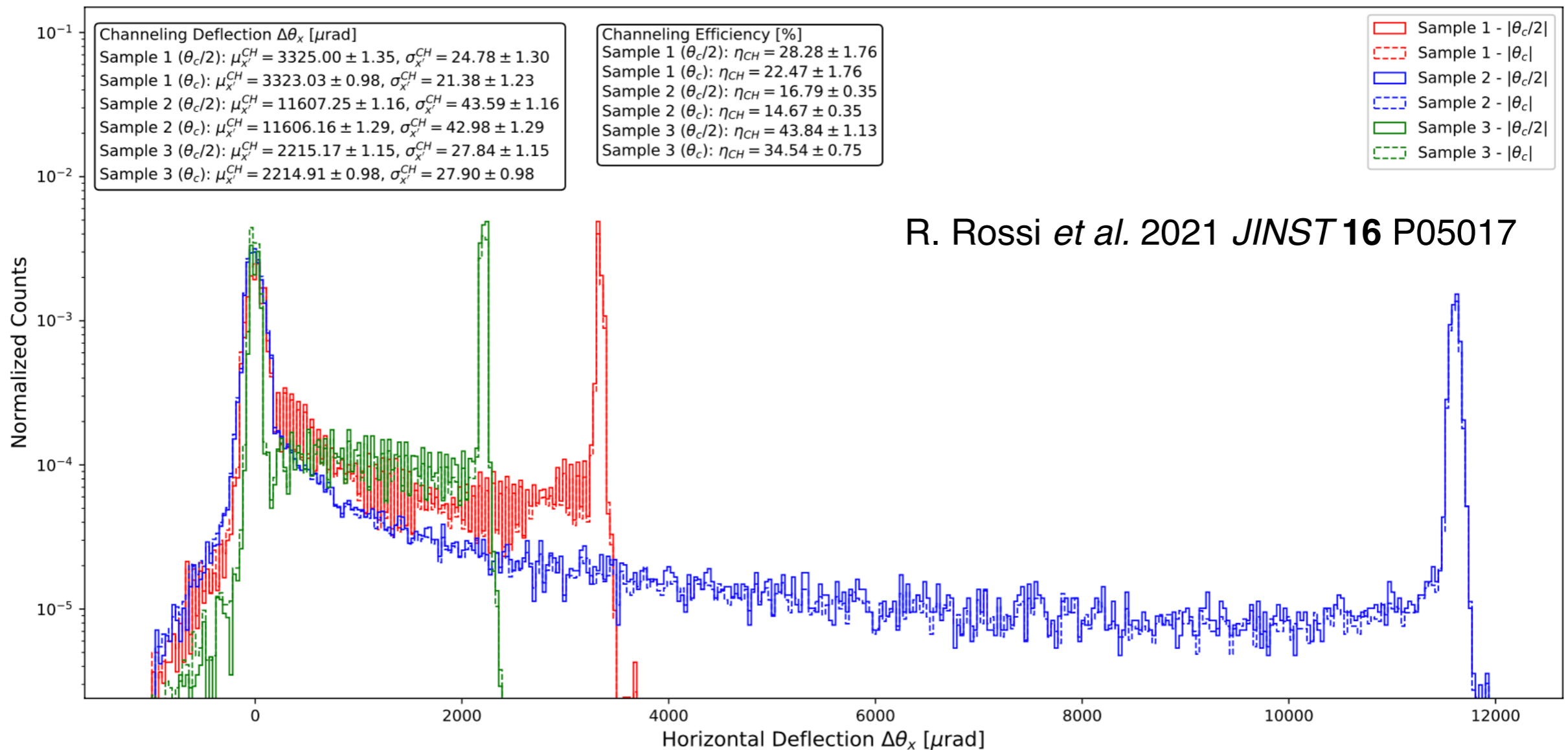

- Si crystals produced at INFN-Ferrara	length (cm)	bending (mrad)	ch. eff. (%)
	8.0	11.6	14.7
	8.0	3.3	22.5
	2.5	2.2	34.5

Fixed-target setup upstream of LHCb

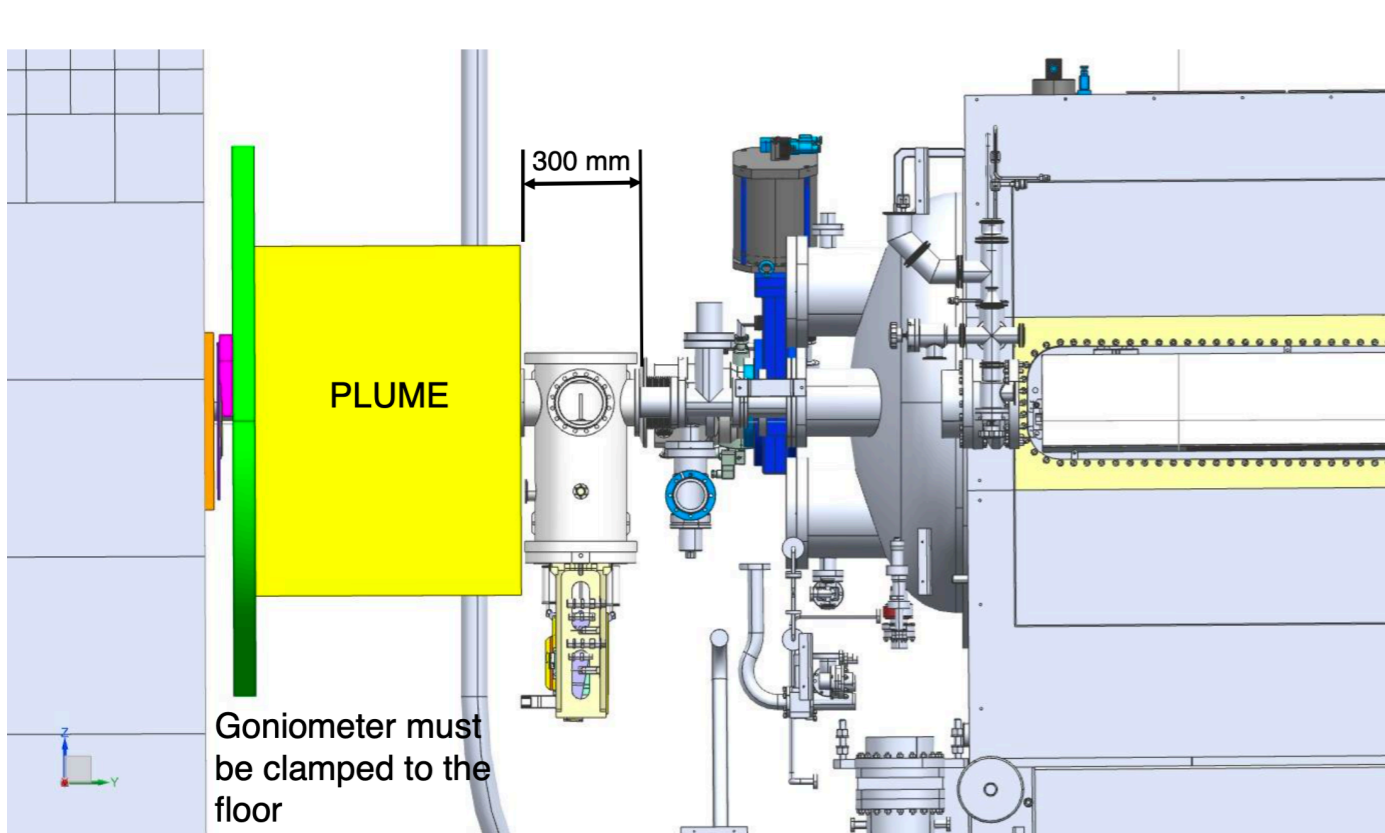

- ▶ Goniometer for target+crystal positioned in the region upstream of the LHCb detector

- ▶ Goniometer internal structure: compatible with operations in ultra-high vacuum
- ▶ Accuracy on position $\sim 20 \mu\text{m}$, rotation angle $\sim 20 \mu\text{rad}$

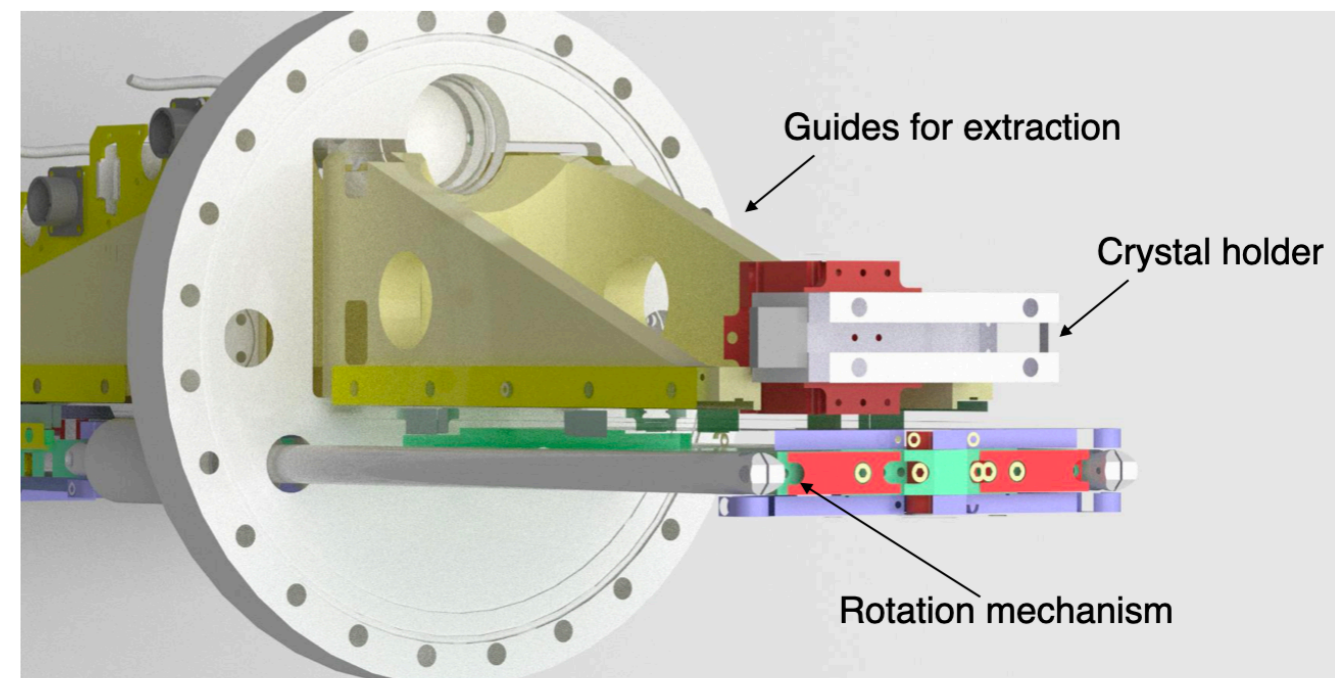

Use copious Λ_c^+ , Ξ_c^+ 3-body decays

- ▶ Use 3-body decays to increase the signal yield
- ▶ Extract maximum information on polarisation via full amplitude analysis of the 3-body baryon decays

D. Marangotto, AHEP (2020) 7463073

D. Marangotto, AHEP (2020) 6674595

PRD 103, 072003 (2021)

Λ_c^+ final state	\mathcal{B} (%)	$\epsilon_{3\text{trk}}$	\mathcal{B}_{eff} (%)
$pK^-\pi^+$	6.28 ± 0.32	0.99	6.25
$\Sigma^+\pi^-\pi^+$	4.50 ± 0.25	0.54	2.43
$\Sigma^-\pi^+\pi^+$	1.87 ± 0.18	0.71	1.33
$p\pi^-\pi^+$	0.461 ± 0.028	1.00	0.46
$\Xi^-K^+\pi^+$	0.62 ± 0.06	0.73	0.45
$\Sigma^+K^-K^+$	0.35 ± 0.04	0.51	0.18
pK^-K^+	0.106 ± 0.006	0.98	0.11
$\Sigma^+\pi^-K^+$	0.21 ± 0.06	0.54	0.11
$pK^-\pi^+\pi^0$	4.46 ± 0.30	0.99	4.43
$\Sigma^+\pi^-\pi^+\pi^0$	3.20	0.54	1.72
$\Sigma^-\pi^+\pi^+\pi^0$	2.1 ± 0.4	0.71	1.49
$\Sigma^+[p\pi^0]\pi^-\pi^+$	2.32	0.46	1.06
$\Sigma^+[p\pi^0]K^-K^+$	0.18	0.46	0.08
$\Sigma^+[p\pi^0]\pi^-K^+$	0.11	0.46	0.05
All	20.2

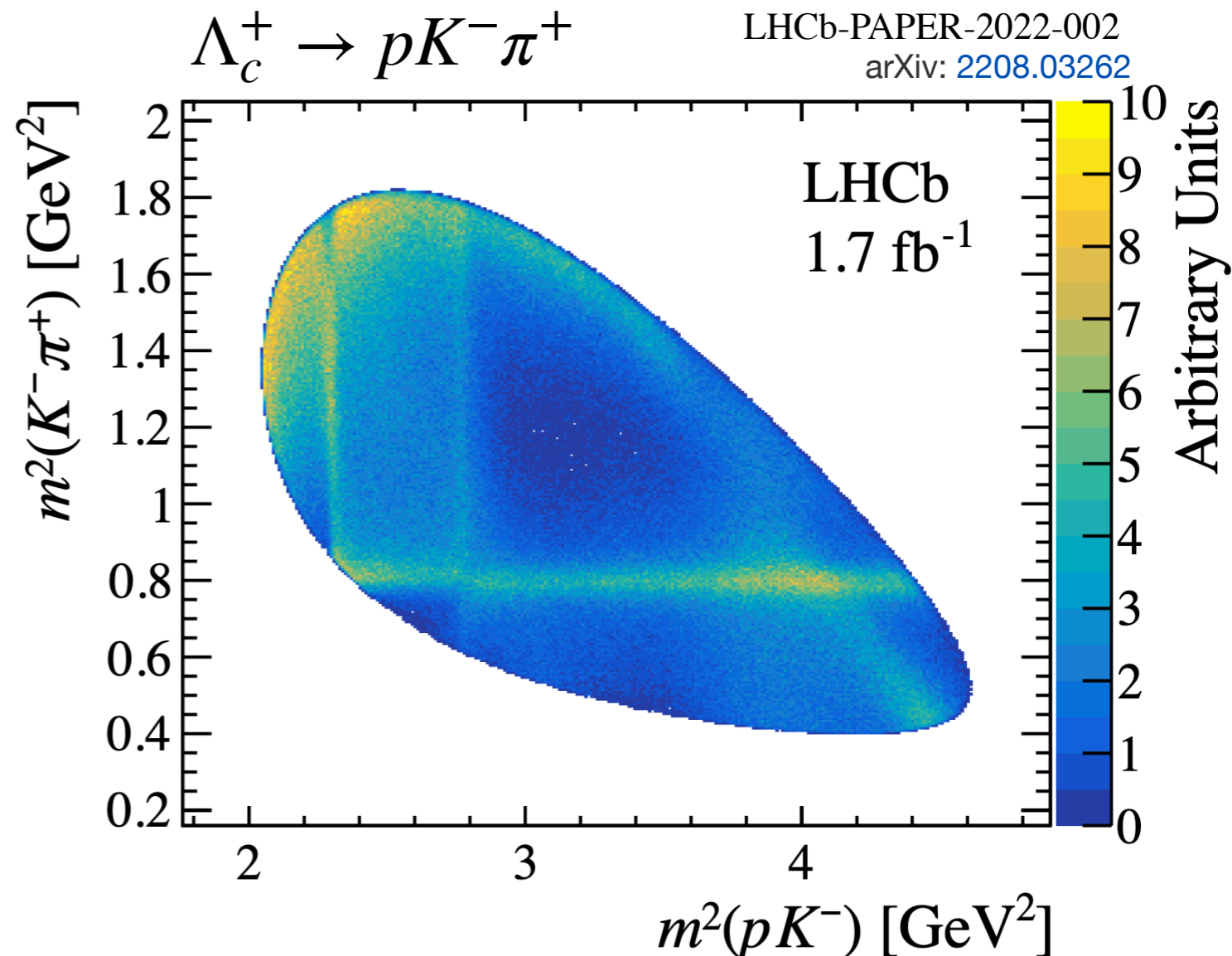

$\Lambda_c^+ \rightarrow p K^- \pi^+$ amplitude analysis

LHCb-PAPER-2022-002
arXiv: 2208.03262

Λ_c^+ selected from semileptonic beauty decays

400k signal yield, 98% purity

Amplitude model

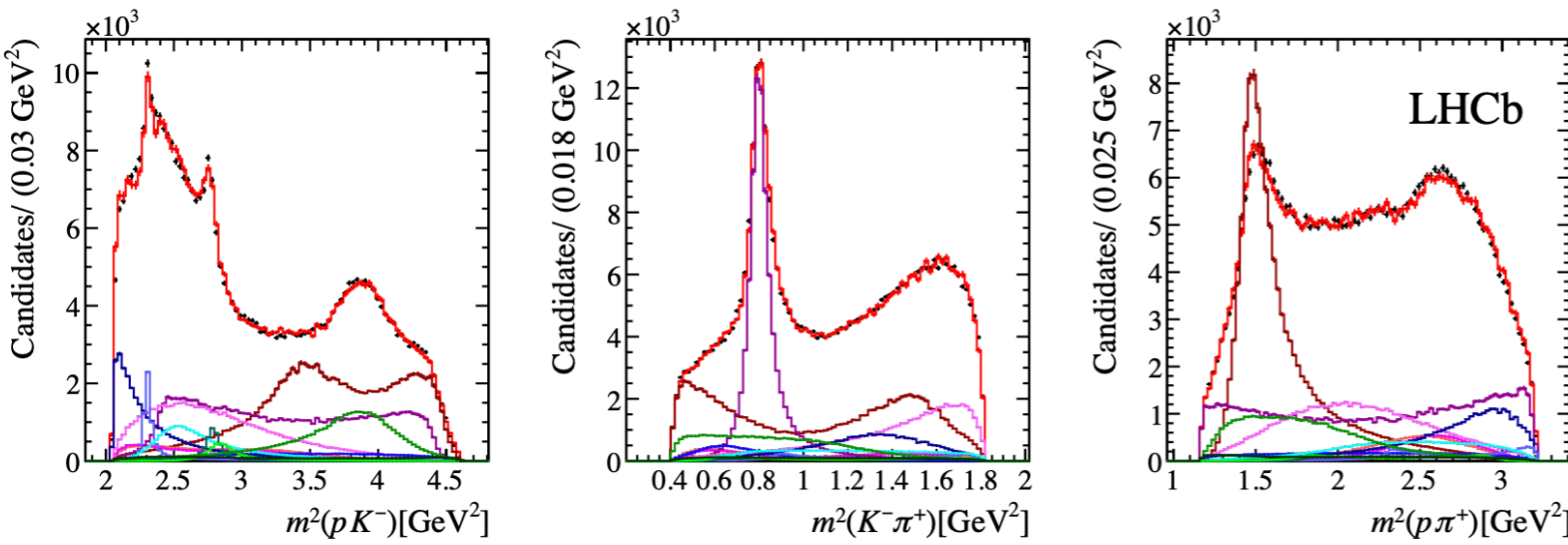

Resonance	J^P	Mass (MeV)	Width (MeV)	Fit Fraction (%)
$\Lambda(1405)$	$1/2^-$	1405.1	50.5	7.7
$\Lambda(1520)$	$3/2^-$	1515 – 1523	10 – 20	1.86
$\Lambda(1600)$	$1/2^+$	1630	250	5.2
$\Lambda(1670)$	$1/2^-$	1670	30	1.18
$\Lambda(1690)$	$3/2^-$	1690	70	1.19
$\Lambda(2000)$	$1/2^-$	1900 – 2100	20 – 400	9.58
$\Delta(1232)^{++}$	$3/2^+$	1232	117	28.60
$\Delta(1600)^{++}$	$3/2^+$	1640	300	4.5
$\Delta(1700)^{++}$	$3/2^-$	1690	380	3.90
$K_0^*(700)$	0^+	824	478	3.02
$K^*(892)$	1^-	895.5	47.3	22.14
$K_0^*(1430)$	0^+	1375	190	14.7

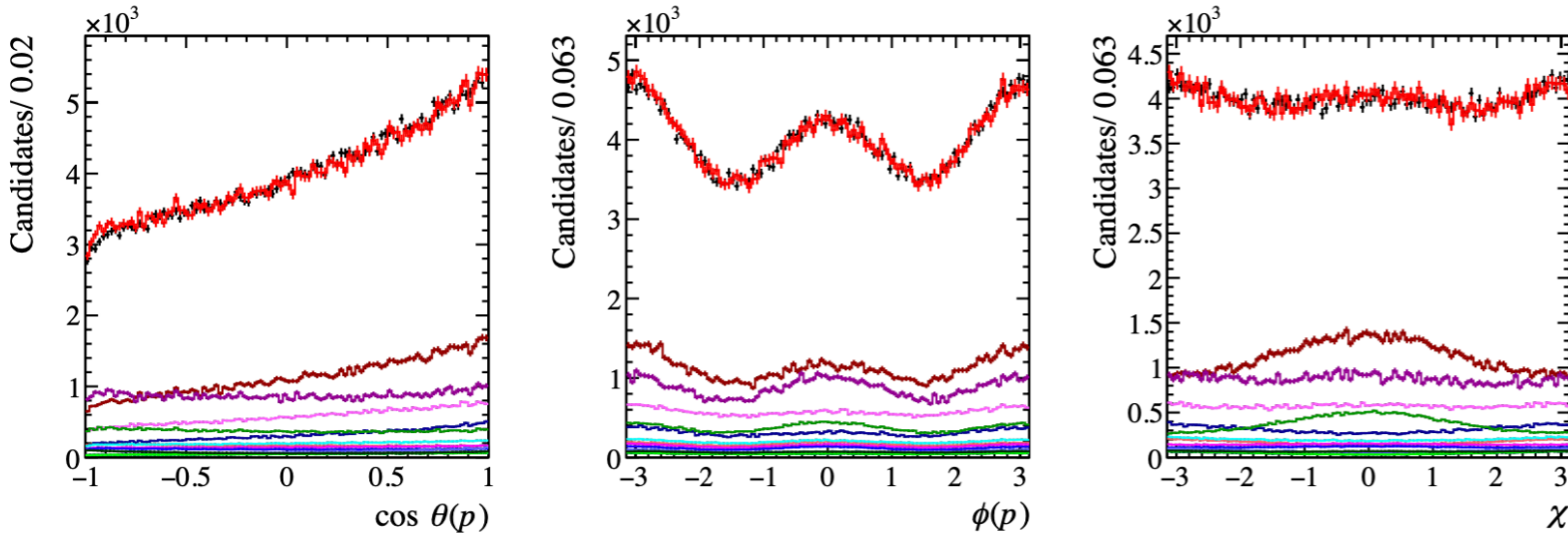

Polarisation measurement

Component	Value (%)
$P_x (lab)$	$60.32 \pm 0.68 \pm 0.98 \pm 0.21$
$P_y (lab)$	$-0.41 \pm 0.61 \pm 0.16 \pm 0.07$
$P_z (lab)$	$-24.7 \pm 0.6 \pm 0.3 \pm 1.1$
$P_x (\tilde{B})$	$21.65 \pm 0.68 \pm 0.36 \pm 0.15$
$P_y (\tilde{B})$	$1.08 \pm 0.61 \pm 0.09 \pm 0.08$
$P_z (\tilde{B})$	$-66.5 \pm 0.6 \pm 1.1 \pm 0.1$

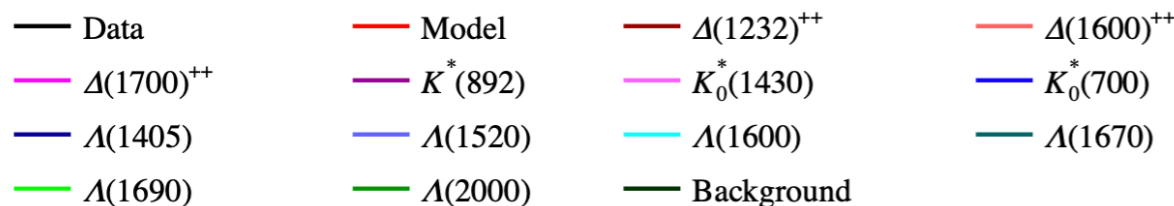

Λ_c^+ polarization in fixed-target collisions

- ▶ Λ_c^+ polarization vs p_T measured in π^- -N at $\sqrt{s}=31$ GeV by E791 experiment

Physics Letters B 471 (2000), 449–459

- ▶ Λ_c^+ **polarization** and **cross-section** in SMOG p-Ne collisions $\sqrt{s}=68.6$ GeV at LHCb in progress (signal yield ≈ 2500)

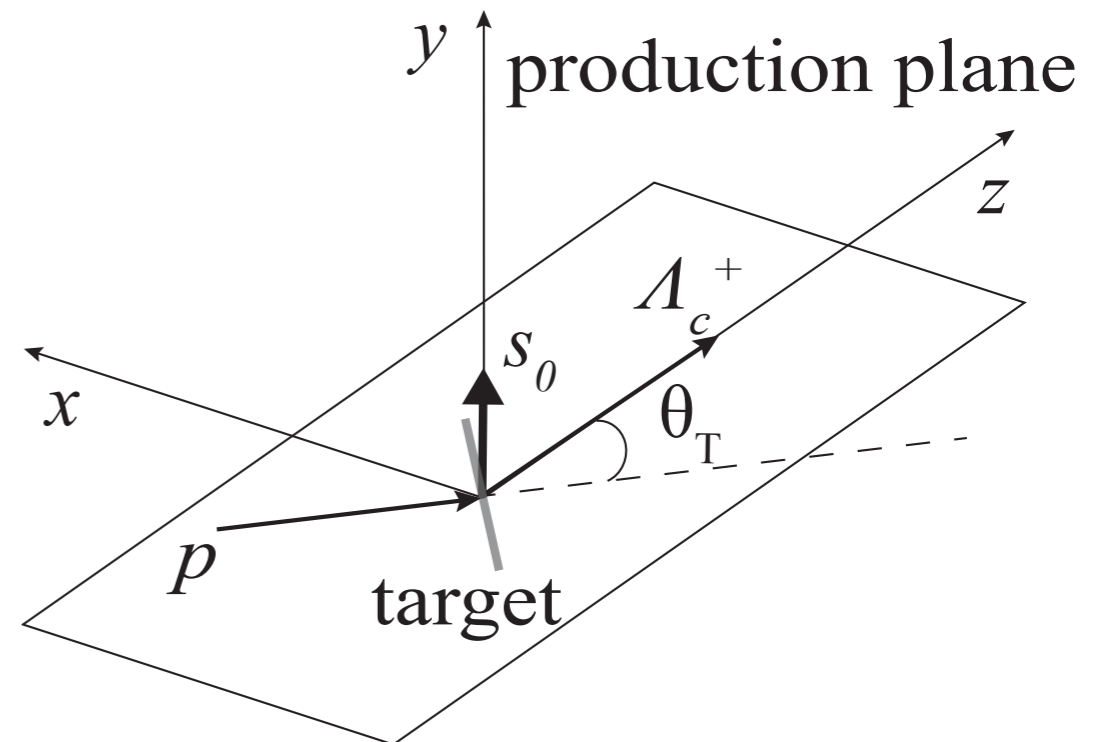
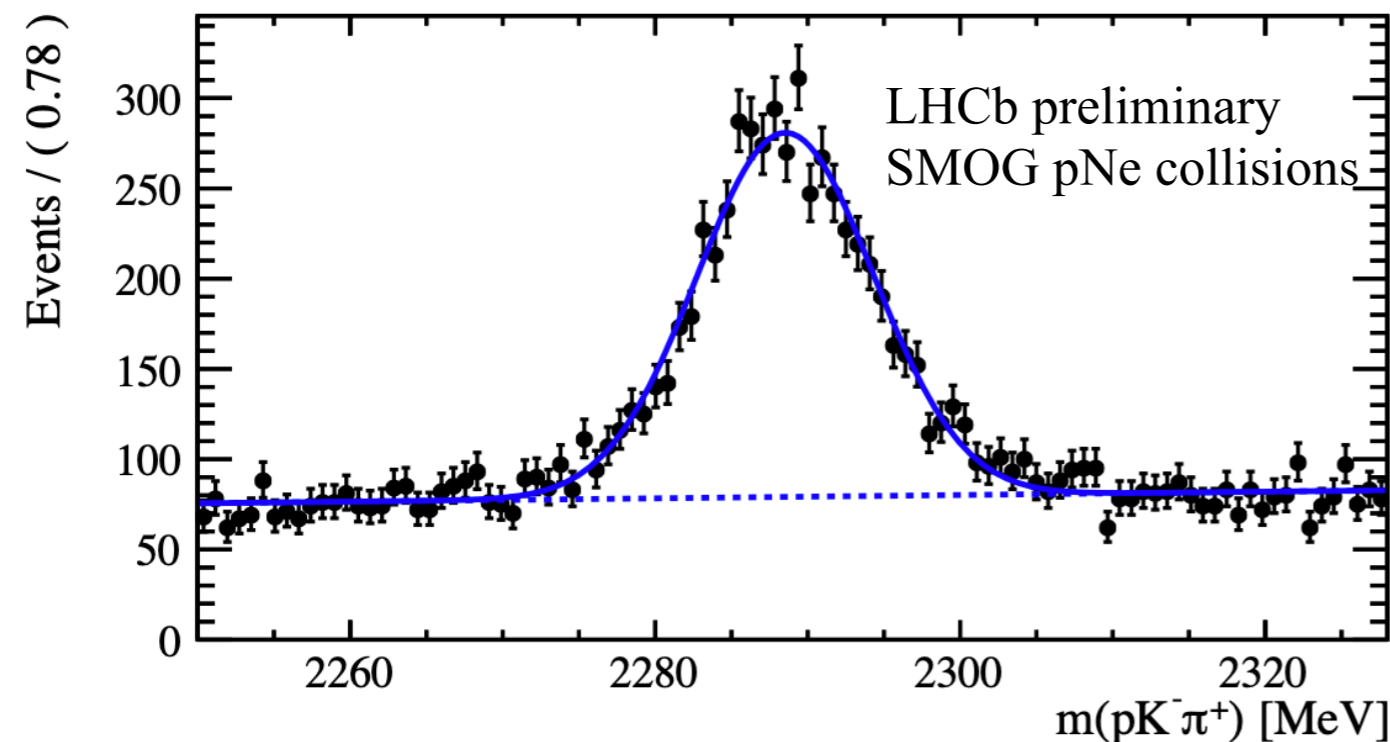
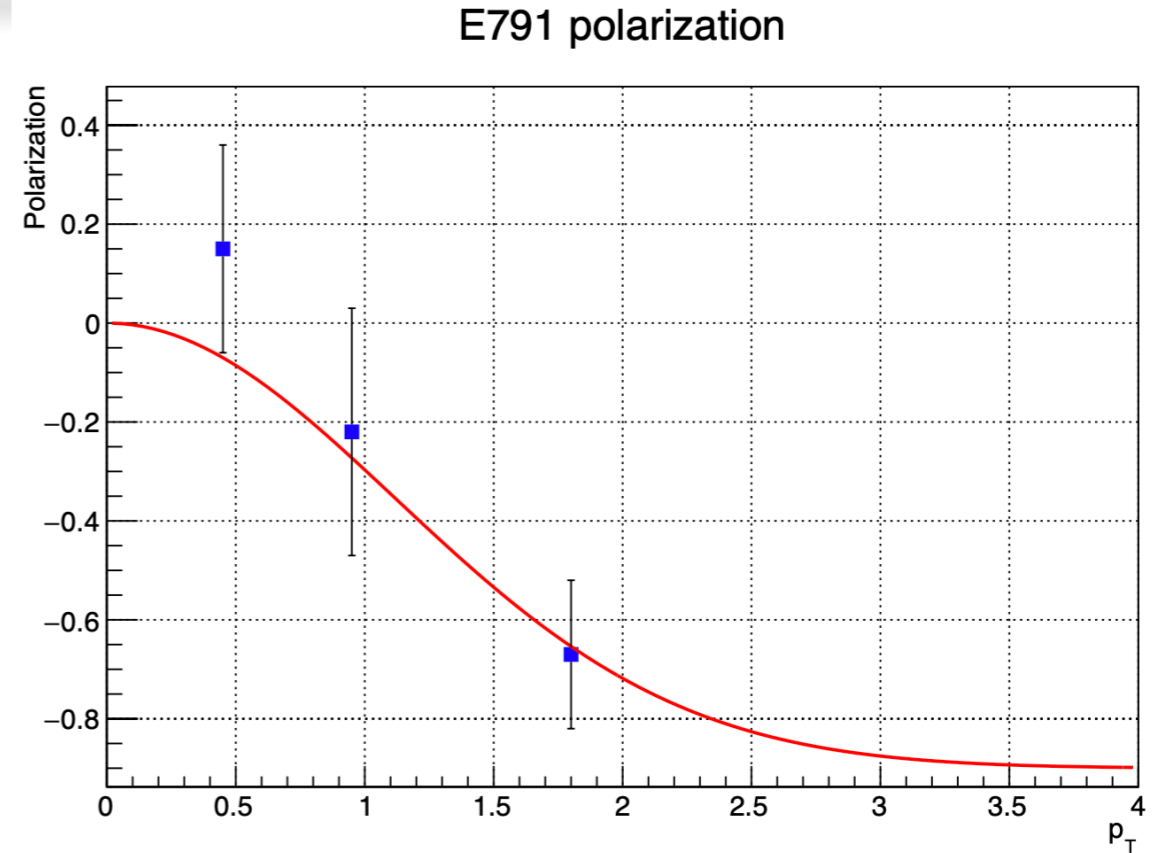

Test in LHC at IR3

- ▶ A **proof-of-principle** test at the insertion region 3 (IR3) is considered with LHC machine people
- ▶ Main goals of the test
 - test machine and operational aspects
 - measure channeling efficiency at TeV energies
 - study detector performance and background level

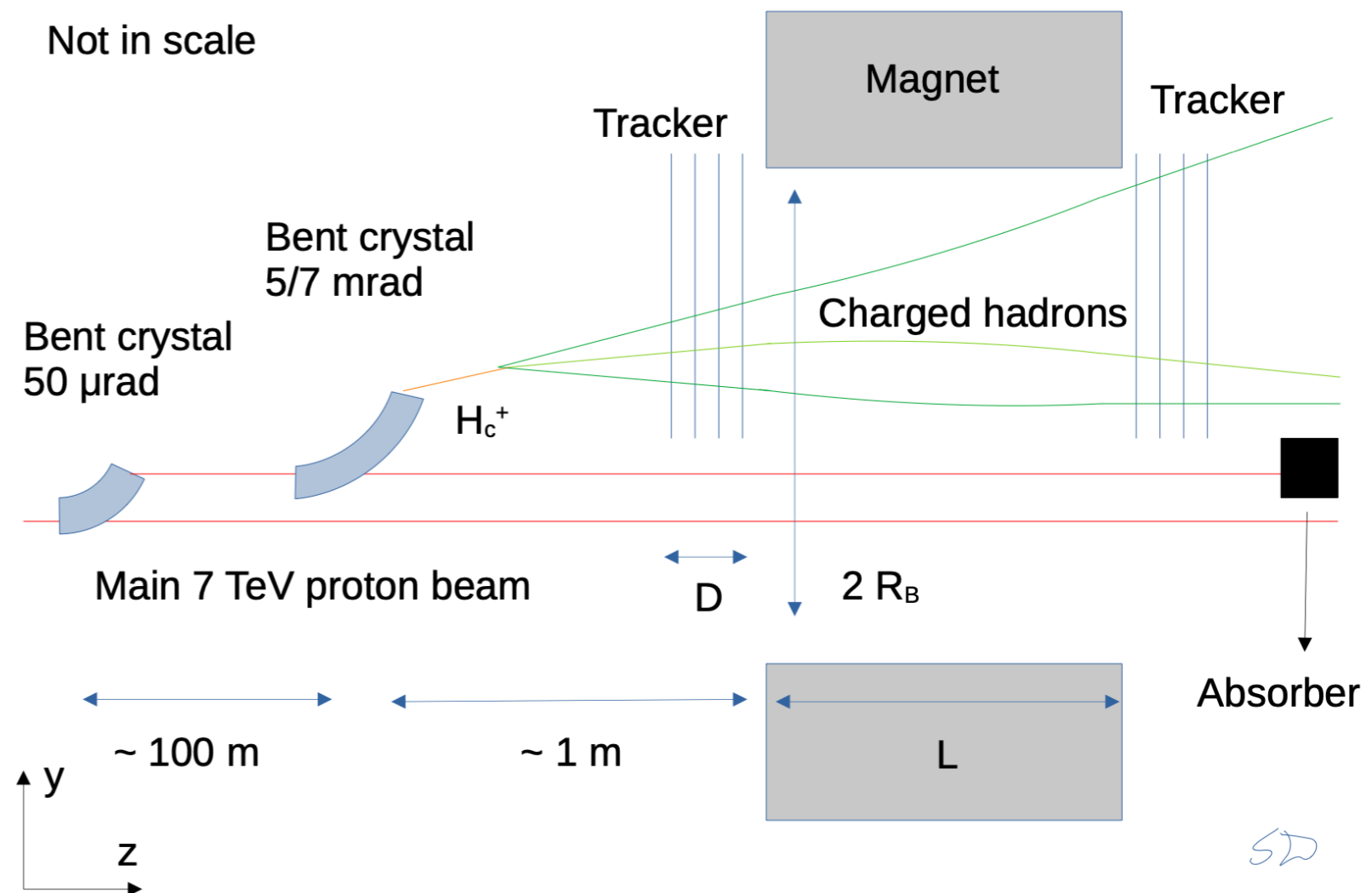

Studies for a dedicated experiment at IR3

- ▶ Channeled Λ_c^+ in bent crystal are very focused in few cm^2
- ▶ Preliminary simulations: with 8 **VELO tiles** + existing 1.9Tm dipole magnet in situ can build a spectrometer

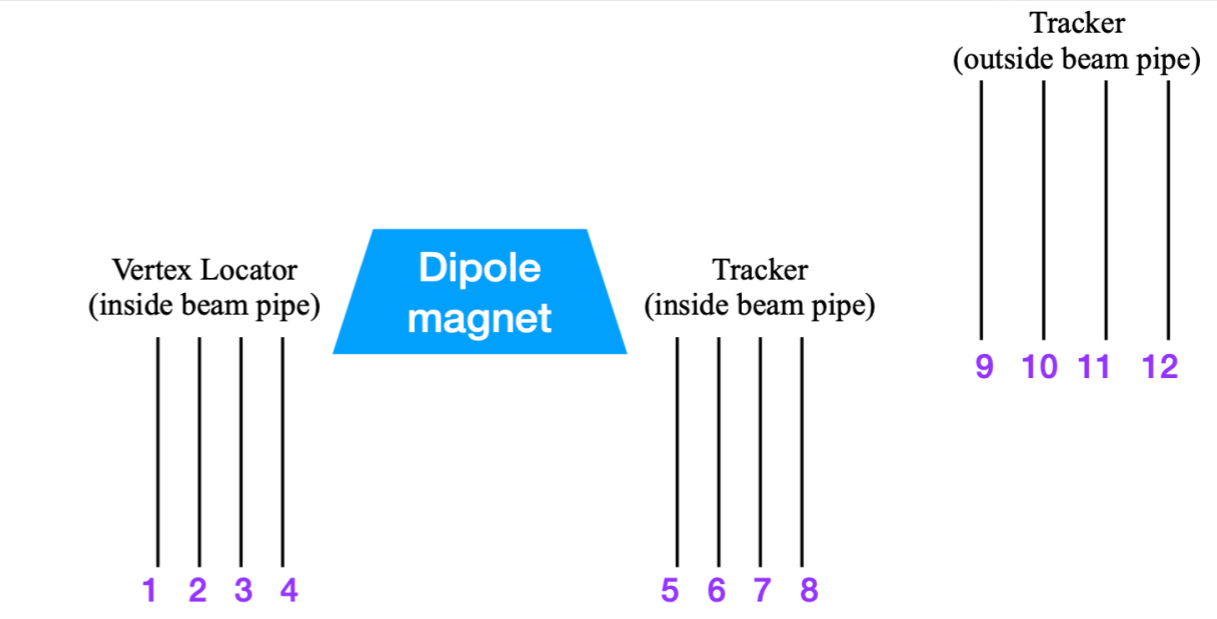

Hit distribution for $\Lambda_c^+ \rightarrow pK^-\pi^+$
 Area \approx few cm^2 . rate \approx 100 MHz/ cm^2

Last tracker station at $z=0.4$ m from magnet

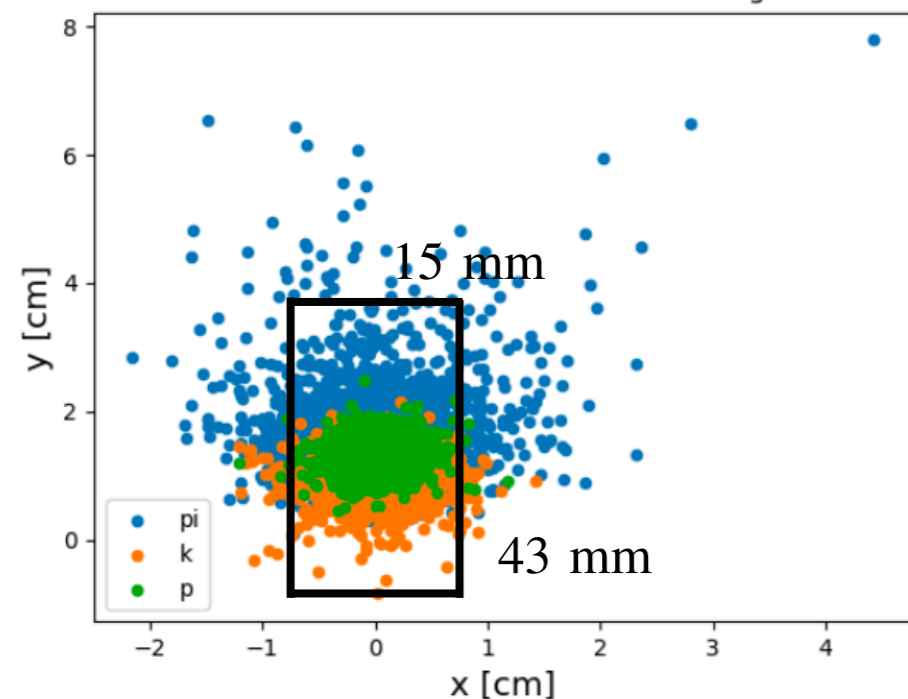

VeloPix modules in Roman Pots

for Vertex and Tracker stations
 1 cm from the beam
 55x55 μm^2 pixel,
 pixel hit rate 600 MHz/ cm^2 ,
 12 μm hit resolution

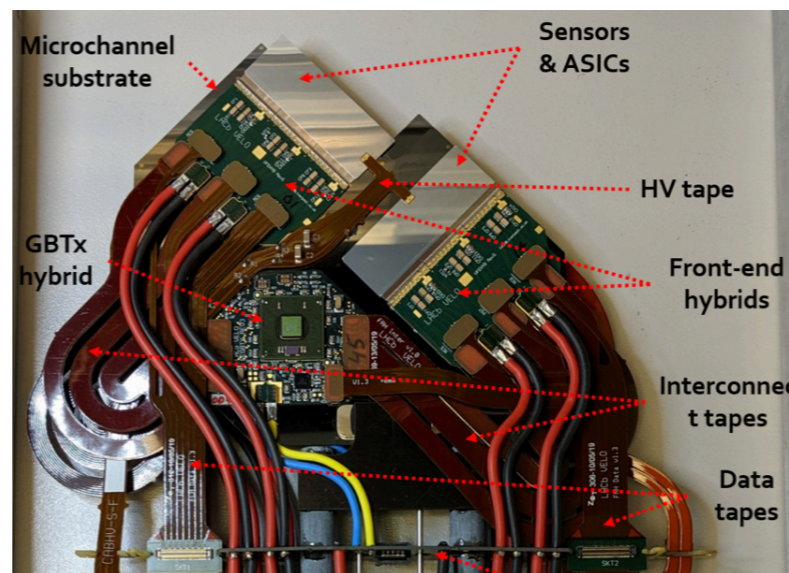

LHC orbit correction dipole MCBW (1.7 m, 1.1 T) is considered for the spectrometer
 (Credits: Pascal Hermes, CERN)

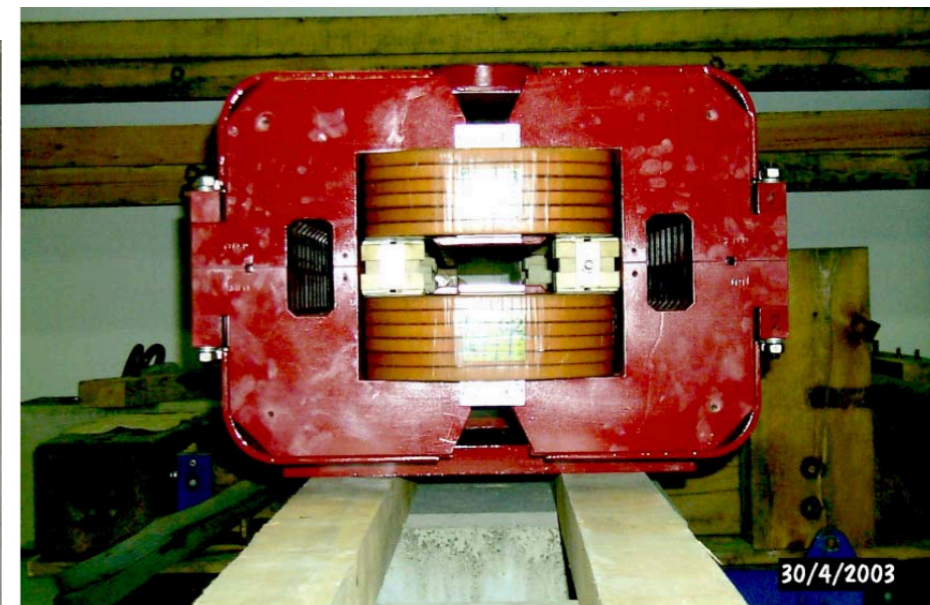

Summary

- ▶ Measurements of **MDM/EDM** of particles are sensitive to physics within and beyond the SM
- ▶ Measurements of MDM/EDM of **long-** and **short-lived particles at LHCb**
- ▶ **First measurements** are possible in 2 year data taking
 - **strange baryons**, using the LHCb detector
 - **charm baryons**, require a fixed-target setup to be installed upstream of the LHCb detector or a dedicated experiment at IR3

Status and next steps

- ▶ **Milestones** achieved: feasibility detector studies, long bent crystal prototypes, preparatory studies in LHCb, machine layout, physics program extended
- ▶ Machine **test in LHC**, possibly during Run3
- ▶ Aim at installation and data taking in **LHCb** for first measurements in the future
- ▶ Design a **dedicated fixed-target** experiment at LHC at high statistics for a more **ambitious physics program**. Potential to study also beauty baryons and tau lepton in the future (much higher statistics is required)
- ▶ If you are interested in **joining** the effort, you are welcome!
Feel free to contact me

Workshop at Villa Feltrinelli in Gargnano del Garda

- ▶ Date: 25-28 Sept. Sessions starts Sept 26th morning [link](#)

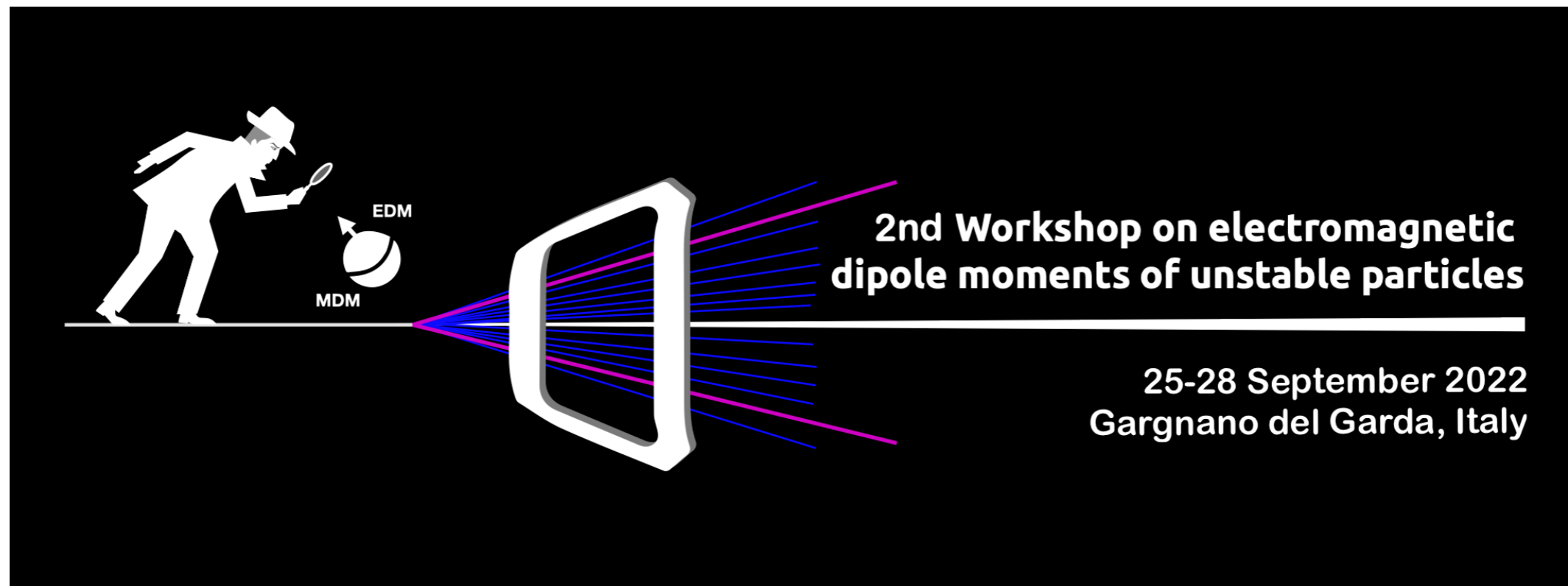

Thanks for your attention!

References for baryons

- S. Aiola, L. Bandiera, G. Cavoto, F. De Benedetti, J. Fu, V. Guidi, L. Henry, D. Marangotto, F. Martinez Vidal, V. Mascagna, J. Mazorra de Cos, A. Mazzolari, A. Merli, N. Neri, M. Prest, M. Romagnoni, J. Ruiz Vidal, M. Soldani, A. Sytov, V. Tikhomirov, E. Vallazza, *Progress towards the first measurement of charm baryon dipole moments*, arXiv:2010.11902 (2020), PRD 103, 072003 (2021) .
- A. S. Fomin, S. Barsuk, A. Yu. Korchin, V.A. Kovalchuk, E. Kou, A. Natochii, E. Niel, P. Robbe, A. Stocchi, *The prospects of charm quark magnetic moment determination*, arXiv:1909.04654 (2020), Eur. Phys. J. C **80**, 358(2020).
- E. Bagli, L. Bandiera, G. Cavoto, V. Guidi, L. Henry, D. Marangotto, F. Martinez Vidal, A. Mazzolari, A. Merli, N. Neri, J. Ruiz Vidal, *Electromagnetic dipole moments of charged baryons with bent crystals at the LHC*, arXiv:1708.08483 (2017), Eur. Phys. J. C **77** (2017) 828.
- A.S. Fomin , A.Yu. Korchin, A. Stocchi, O.A. Bezshyyko, L. Burmistrov, S.P. Fomin, I.V. Kirillin, L. Massacrier , A. Natochii, P. Robbe, W. Scandale, N.F. Shul'ga, *Feasibility of measuring the magnetic dipole moments of the charm baryons at the LHC using bent crystals*, JHEP **1708** (2017) 120.
- V. G. Baryshevsky, *On the search for the electric dipole moment of strange and charm baryons at LHC and parity violating (P) and time reversal (T) invariance violating spin rotation and dichroism in crystal*, arXiv:1708.09799 (2017).
- L. Henry, D. Marangotto, F. Martinez Vidal, A. Merli, N. Neri, P. Robbe, J. Ruiz Vidal, CERN- LHCb-INT-2017-011, *Proposal to search for baryon EDMs with bent crystals at LHCb*.
- F. J. Botella, L. M. Garcia Martin, D. Marangotto, F. Martinez Vidal, A. Merli, N. Neri, A. Oyanguren, J. Ruiz Vidal, *On the search for the electric dipole moment of strange and charm baryons at LHC*, Eur. Phys. J. C **77** (2017) 181.
- L. Burmistrov, G. Calderini, Yu Ivanov, L. Massacrier, P. Robbe, W. Scandale, A. Stocchi, *Measurement of short living baryon magnetic moment using bent crystals at SPS and LHC*, CERN-SPSC-2016-030 ; SPSC-EOI-012.
- V. G. Baryshevsky, *The possibility to measure the magnetic moments of short-lived particles (charm and beauty baryons) at LHC and FCC energies using the phenomenon of spin rotation in crystals*, Phys. Lett. B**757** (2016) 426.

References for τ lepton

- J. Fu, M. A. Giorgi, L. Henry, D. Marangotto, F. Martinez Vidal, A. Merli, N. Neri, J. Ruiz Vidal, *Novel method for the direct measurement of the τ lepton dipole moments*, Phys. Rev. Lett. 123, 011801 (2019)
- A.S. Fomin, A. Korchin, A. Stocchi, S. Barsuk, P. Robbe, *Feasibility of τ lepton electromagnetic dipole moments measurements using bent crystals at LHC*, J. High Energ. Phys. (2019) 2019: 156.

Backup slides

Armenteros-Podolanski plot

- ▶ Simulations for $\Lambda \rightarrow p\pi^-$ and $K_S^0 \rightarrow \pi^+\pi^-$ decays (left).
 $\Lambda \rightarrow p\pi^-$ signal candidates after BDT selection (right)

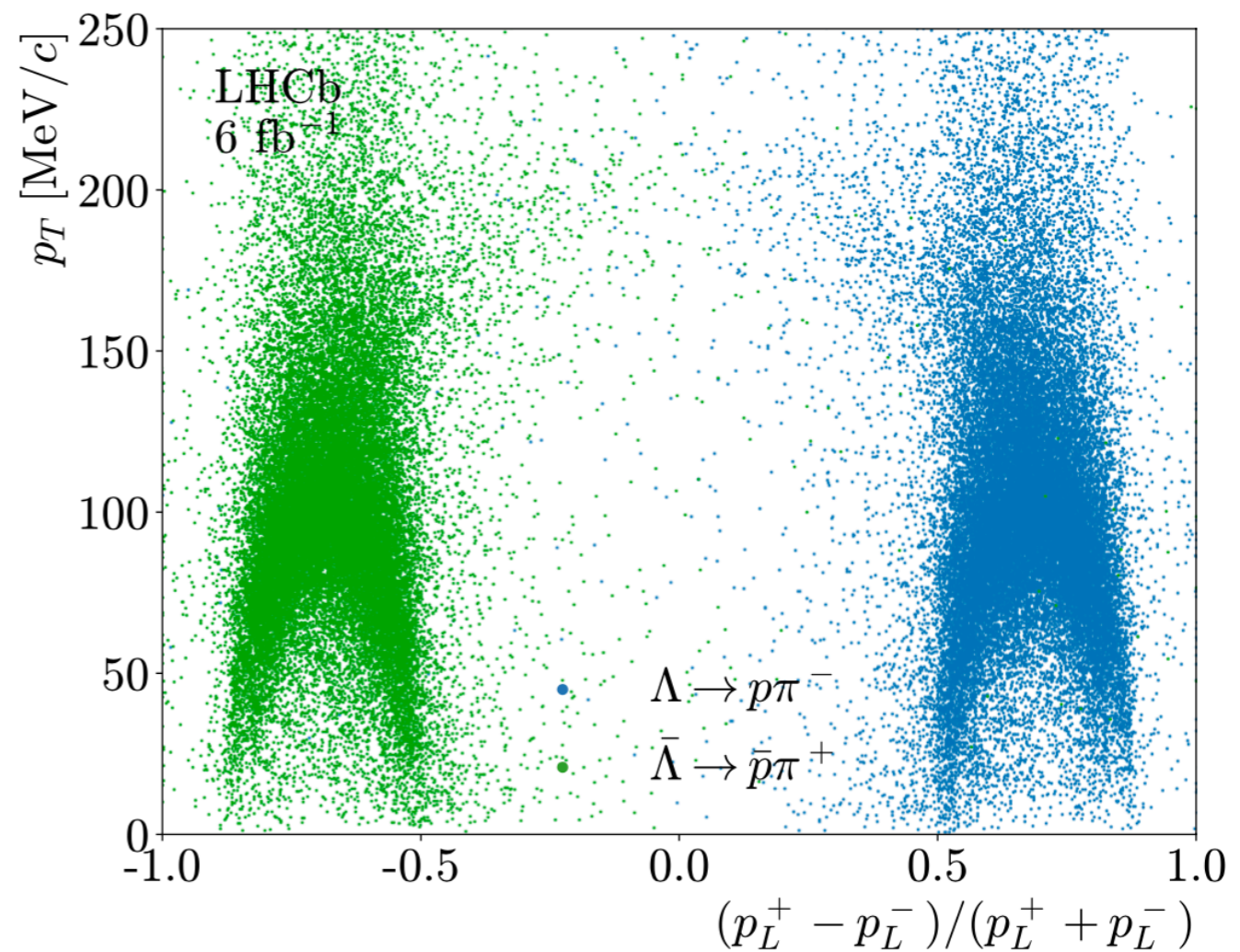
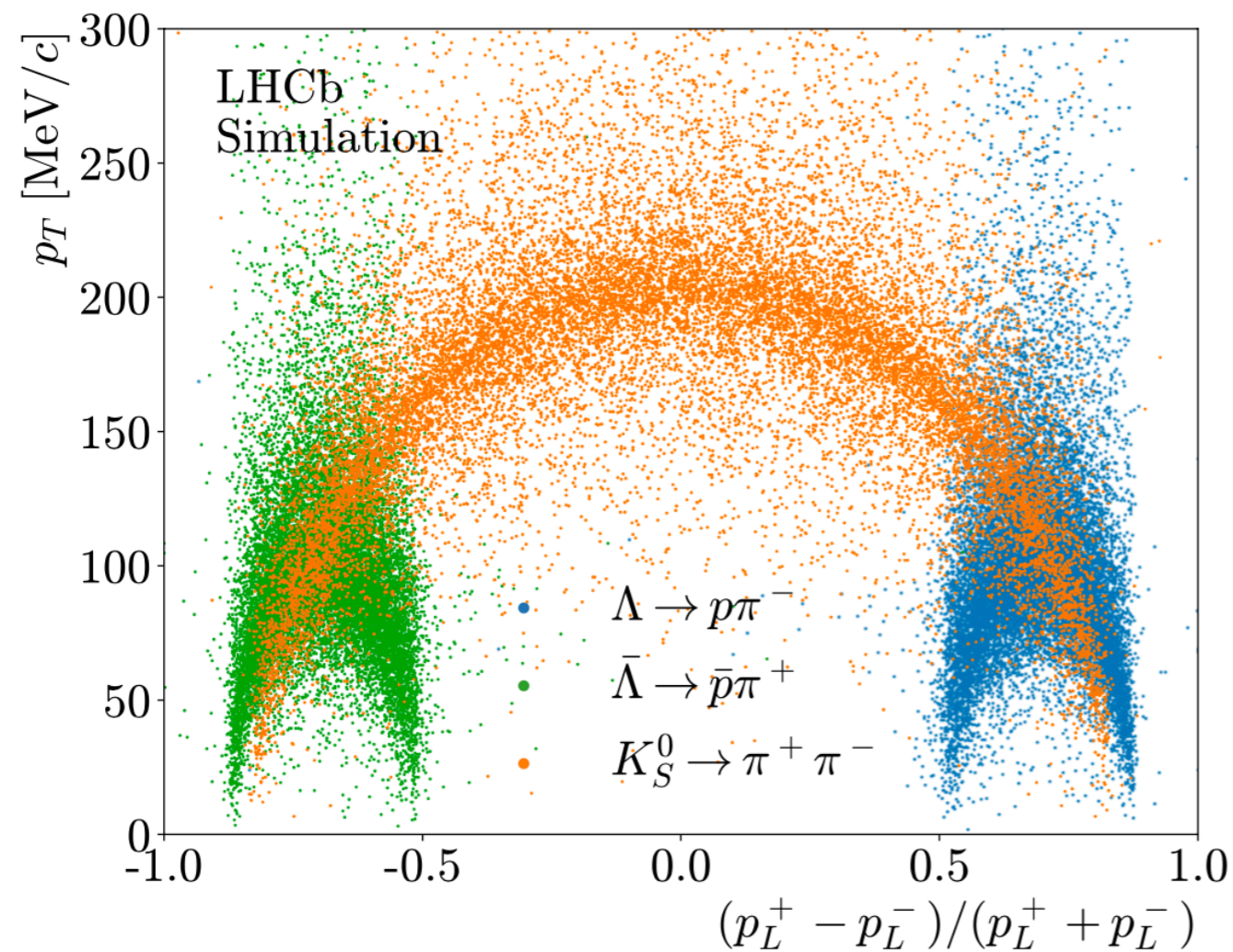

Layout for dedicated experiment

D. Mirarchi, A. S. Fomin, S. Redaelli, W. Scandale EPJC 80 (2020) 10, 929

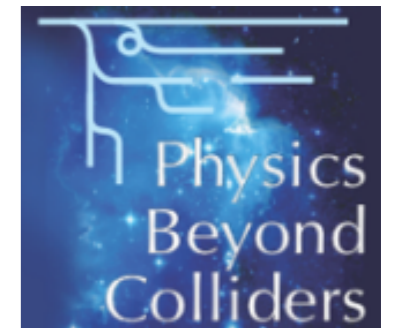
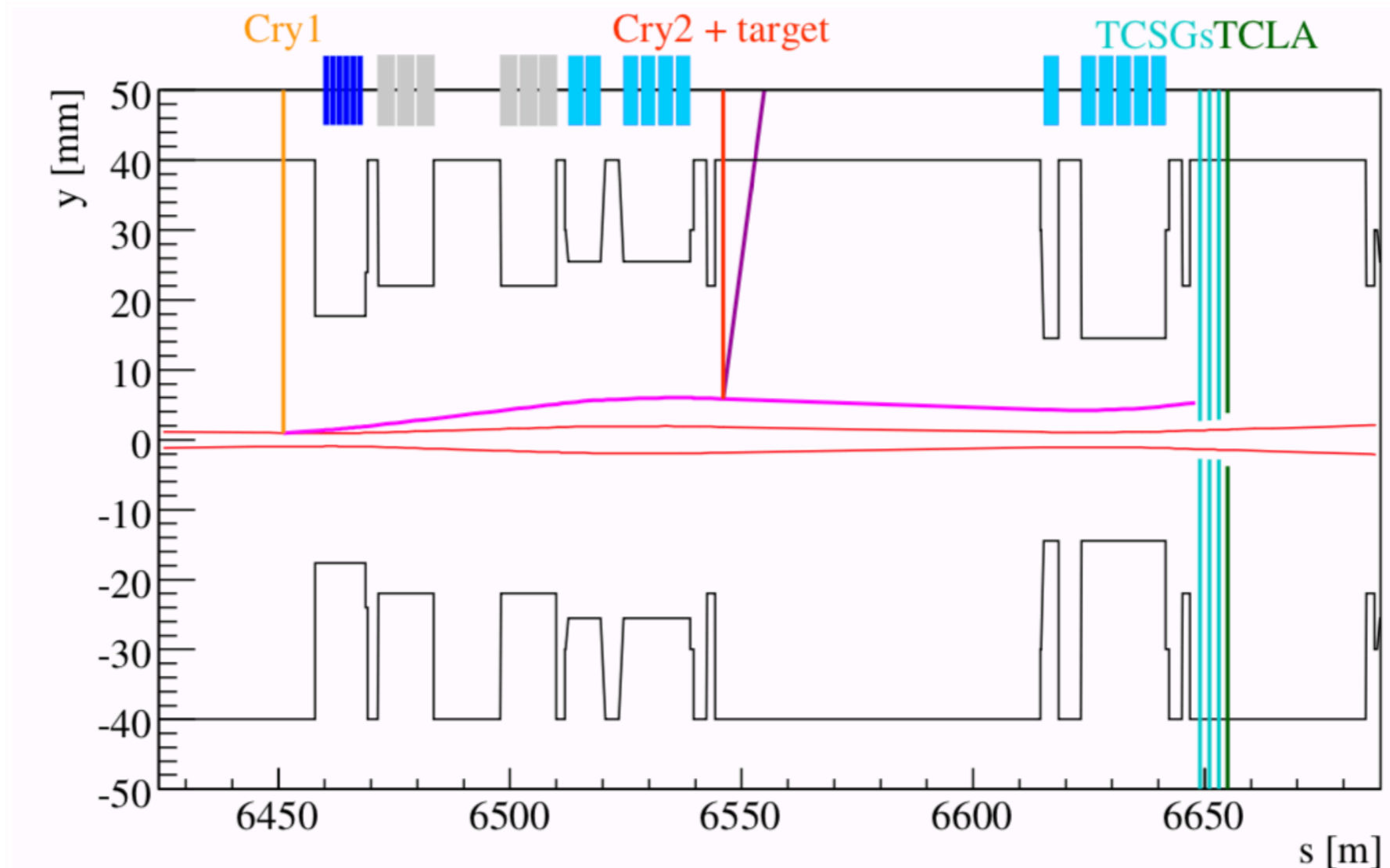
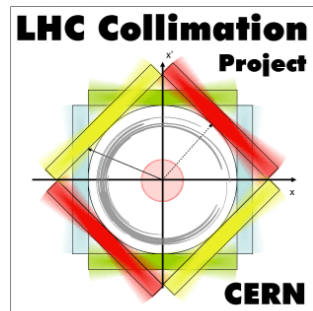

- ▶ At IR3 with optimised detector acceptance and reduced crystal bending (5 mrad), about x100 channeled particles can be achieved

MDM of short-lived baryons

▶ Charm baryon MDM with bent crystals

firstly studied in:

- I. J. Kim, Nucl. Phys B 229 (1983) 251-268
- V. V. Baublis et al., NIMB 90 (1994) 112-118
- V. M. Samsonov, NIMB 119 (1996) 271-279

▶ Revisited for LHC energies:

- V. M. Baryshevsky, PLB 757 (2016) 426–429, NIMB 402, 5 (2017)
- L. Burmistrov et al., Tech. Rep. CERN-SPSC-2016-030 (2016)
- A. S. Fomin et al., JHEP 08 (2017) 120

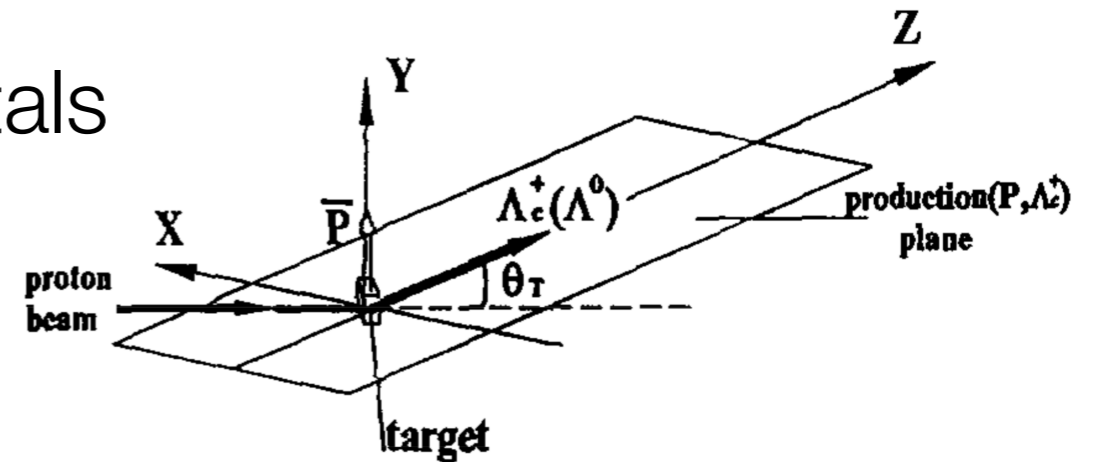

Fig. 3. Schematic diagram of the Λ_c^+ (Λ^0) polarization production.

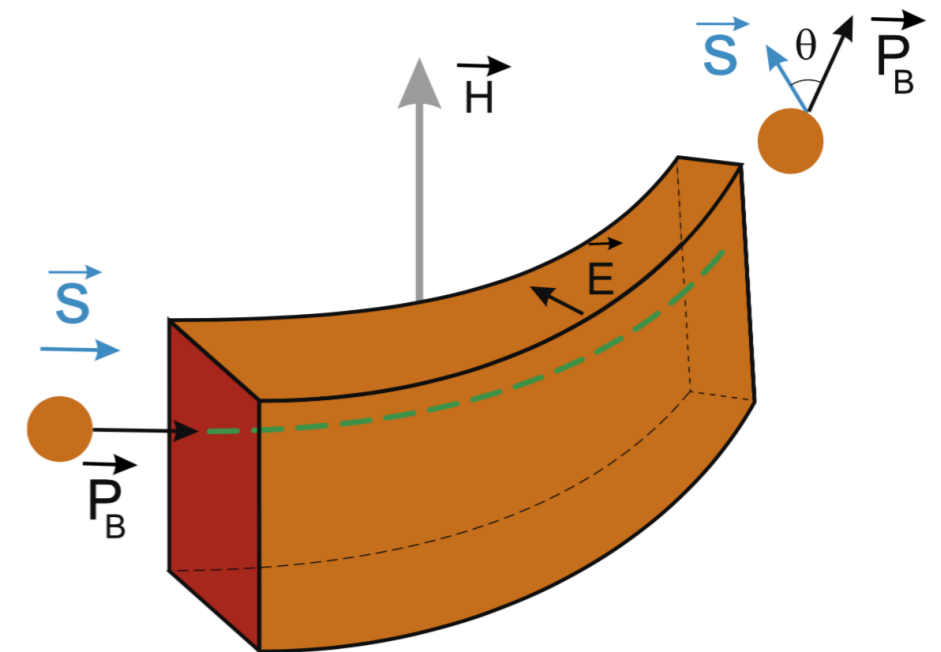

Fig. 1. Spin rotation in a bent crystal.

Proof of principle at Fermilab

- ▶ E761 Fermilab experiment firstly observed **spin precession** in bent crystals and measured MDM of Σ^+
- ▶ **350 GeV/c Σ^+** produced from interaction of 800 GeV/c proton beam on Cu target
- ▶ Used **upbent** and **downbent** silicon **crystals** $L=4.5\text{cm}$, $\theta_c=1.6\text{ mrad}$ for opposite spin precession, reduced systematics

D. Chen et al., Phys. Rev. Lett. 69 (1992) 3286

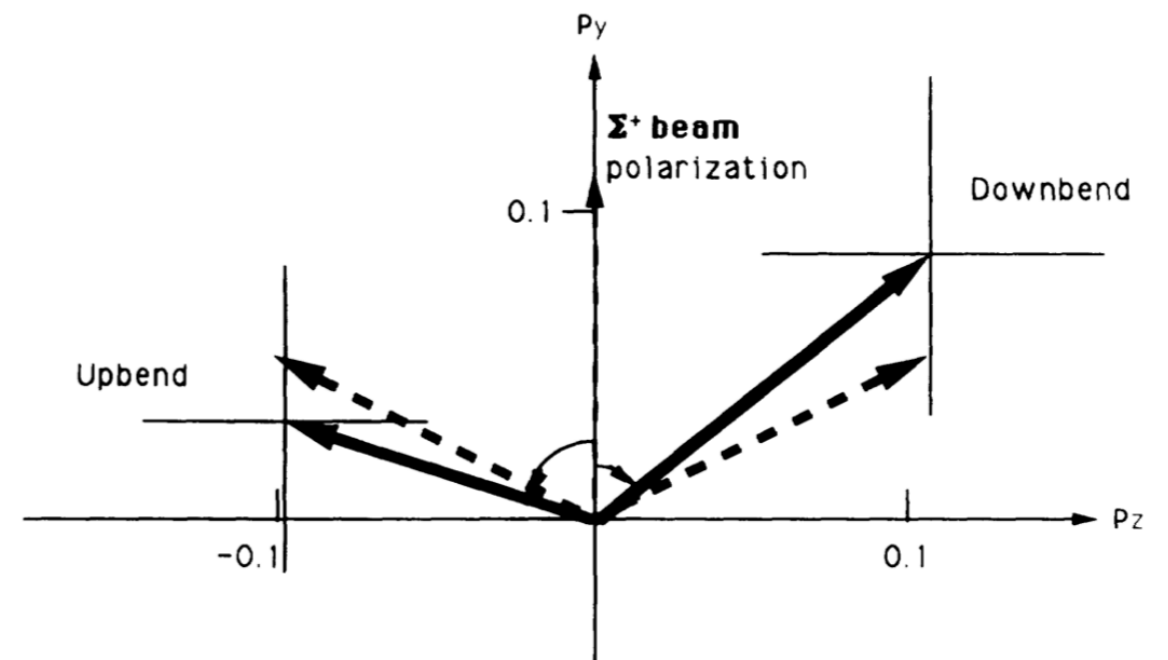
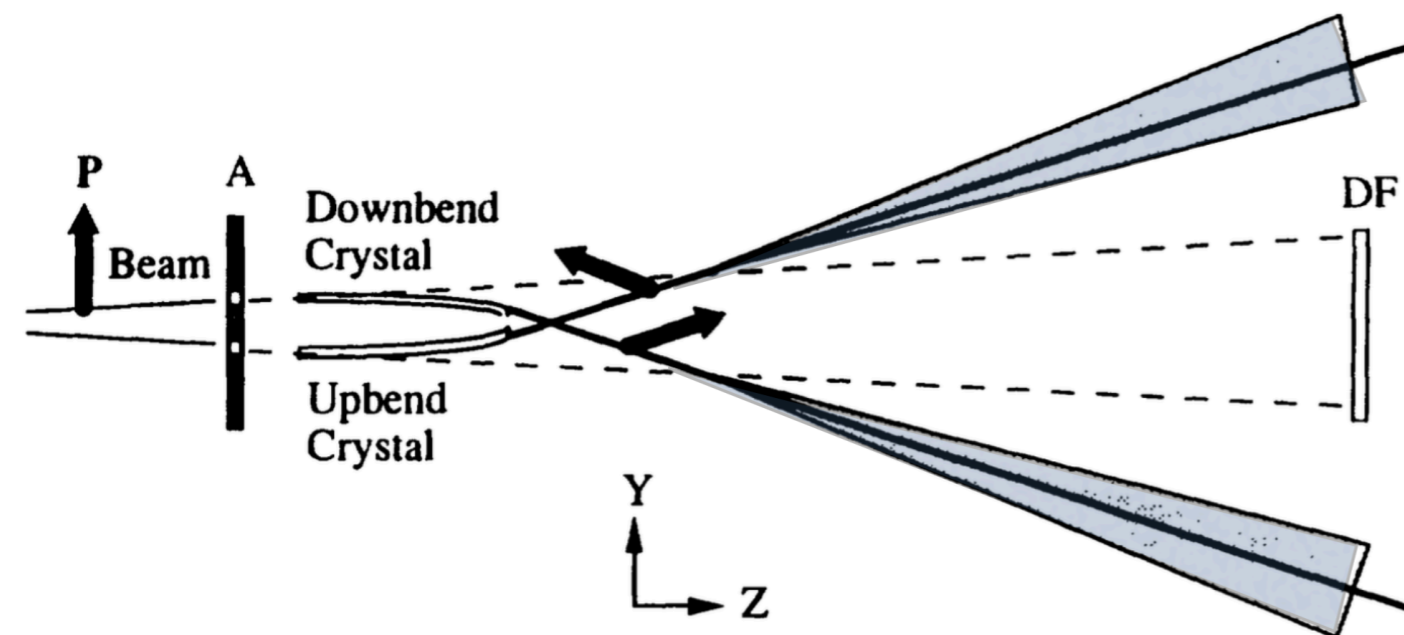
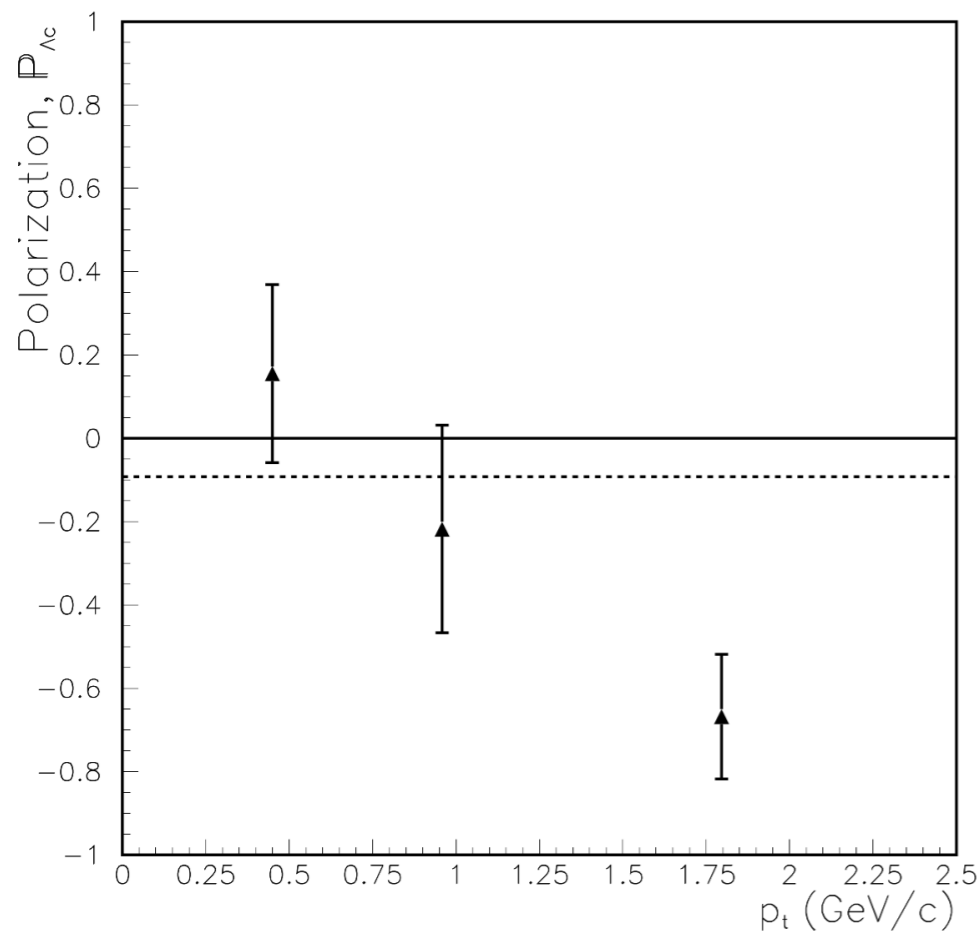
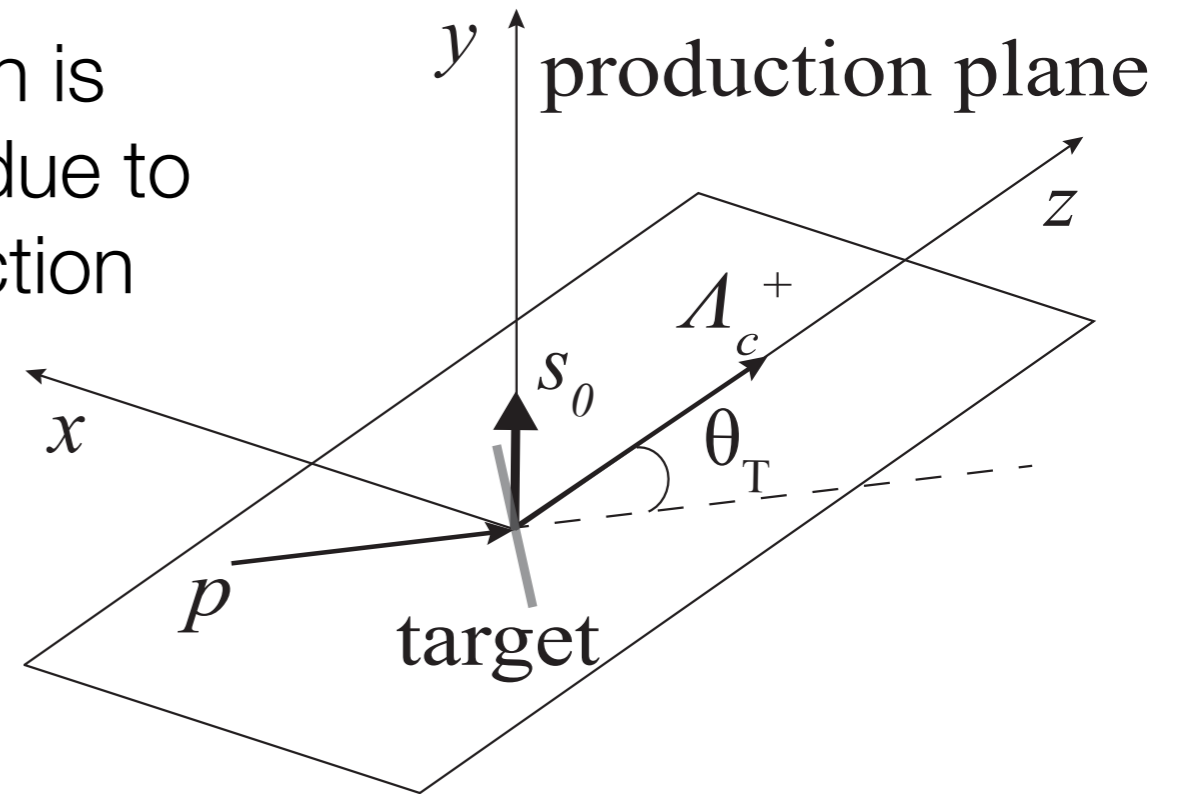

FIG. 3. Measured polarizations and uncertainties (1σ statistical errors) after spins have been precessed by the two crystals. The dashed arrows show the expected precessions.

Charm baryon polarisation

- ▶ Fixed-target production: polarisation is perpendicular to production plane due to parity conservation in strong interaction



- ▶ Λ_c^+ polarisation vs transverse momentum measured by E791 experiment in 500 GeV/c π^- -N reactions
- ▶ Increases with Λ_c^+ transverse momentum

X

Channeling simulations: Ge provides better steering efficiency wrt Si, especially if cooled at $T=77$ K. R&D on **cryogenic Ge crystals** in progress

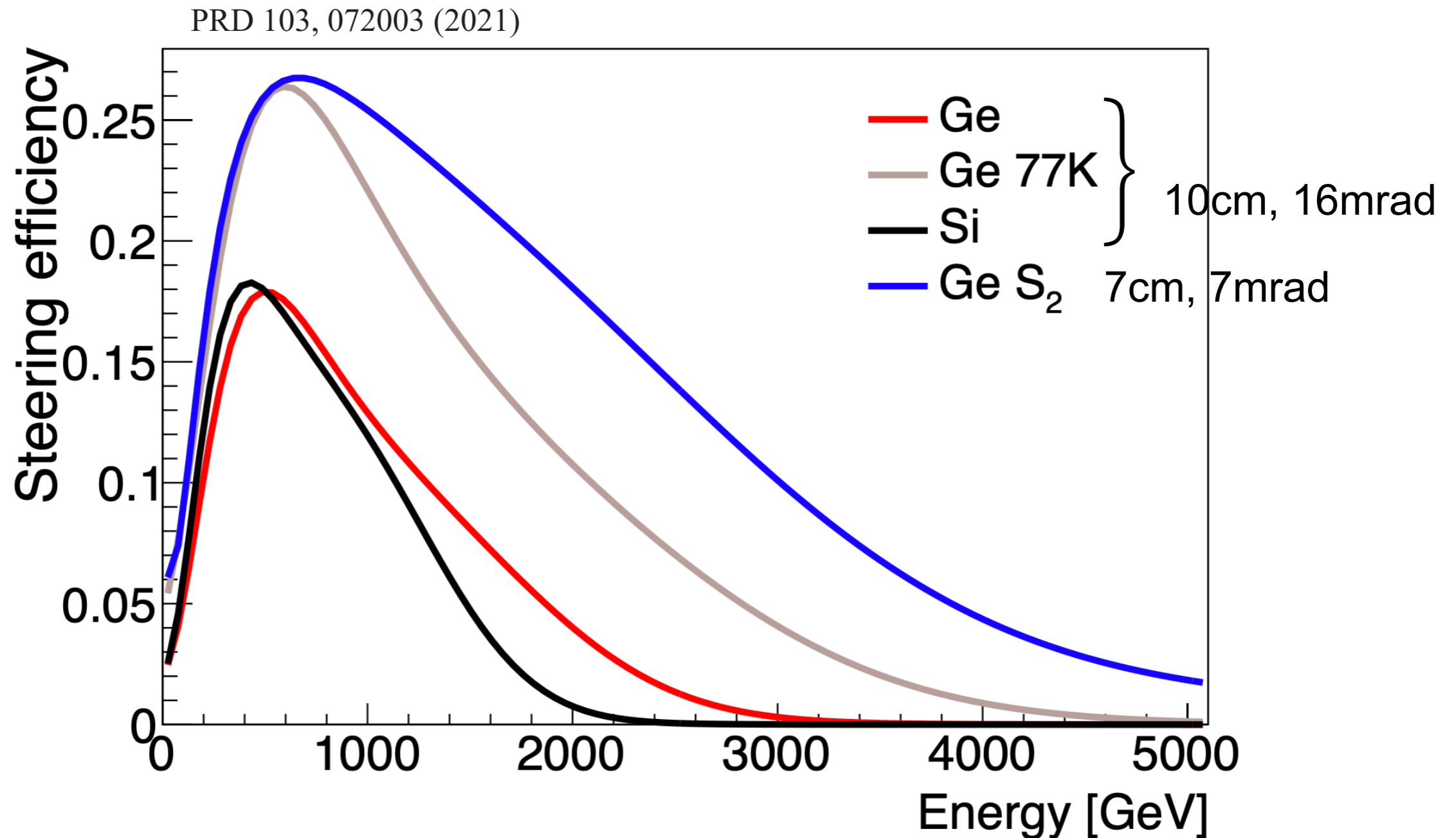

Channeling efficiency vs energy

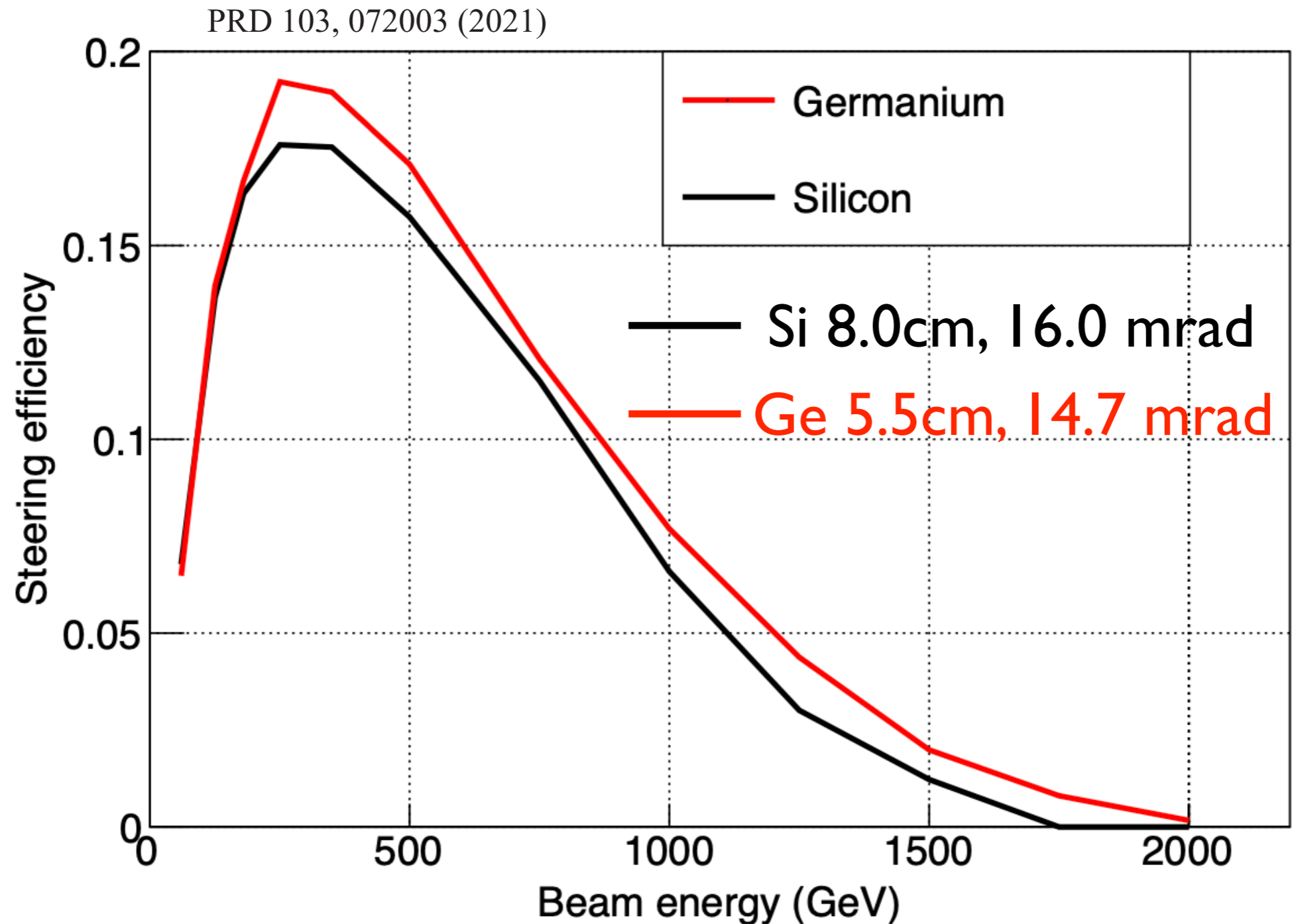

Detector simulation studies

Simulation studies

- ▶ Tungsten (W) 5 mm fixed target + bent crystal positioned in $(0, 0.4, -116)$ cm, before the interaction point

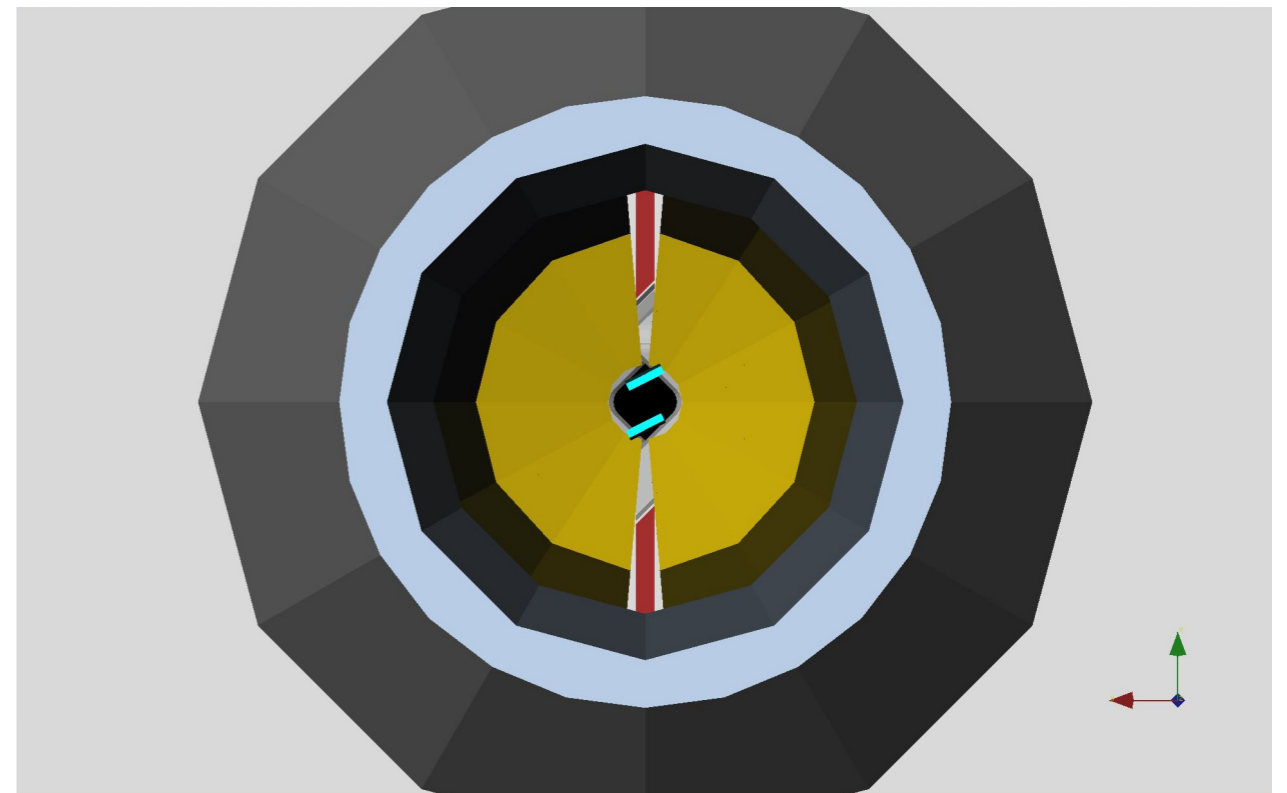
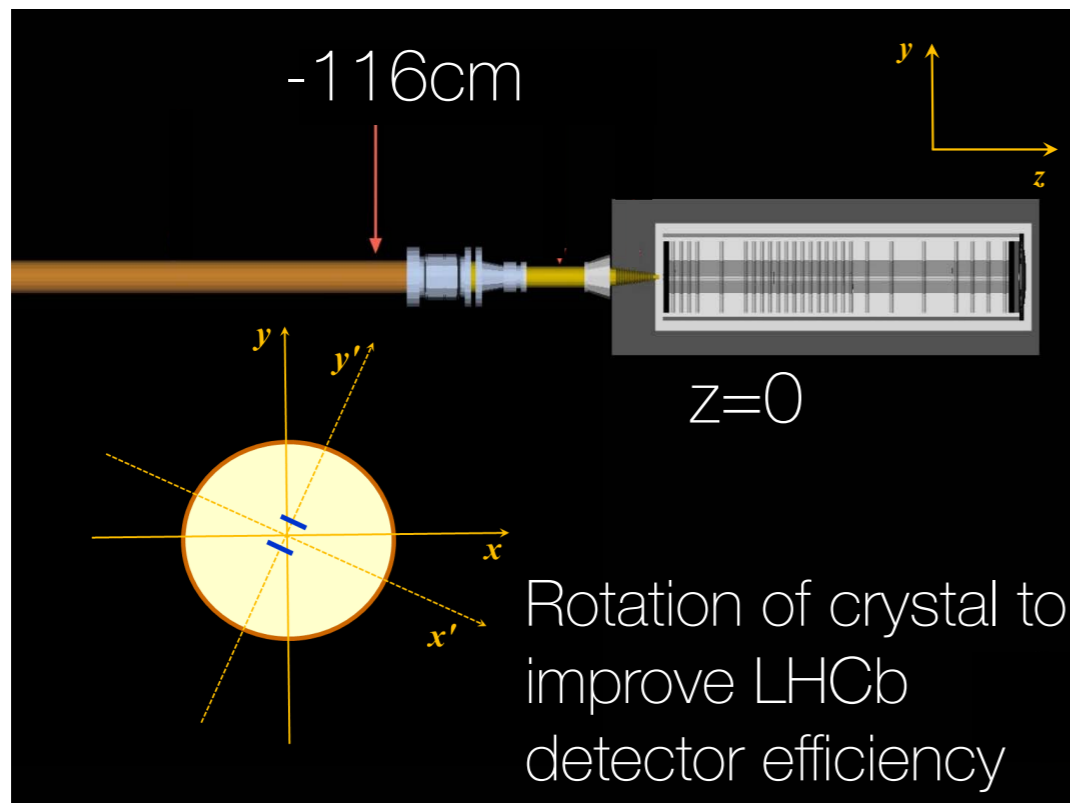

- ▶ Use EPOS for fixed-target minimum bias events, PYTHIA for baryons produced in pW hard collisions
- ▶ Signal reconstruction and background rejection studied using LHCb full simulation

Fixed-target simulation

- ▶ Radiography of the target in (0, 0.3, -116) cm
- ▶ Distribution of origin vertex of stable charged particles in simulated events
- ▶ Simulated processes include: hadronic interactions, pair production, Bremsstrahlung, Compton, δ rays

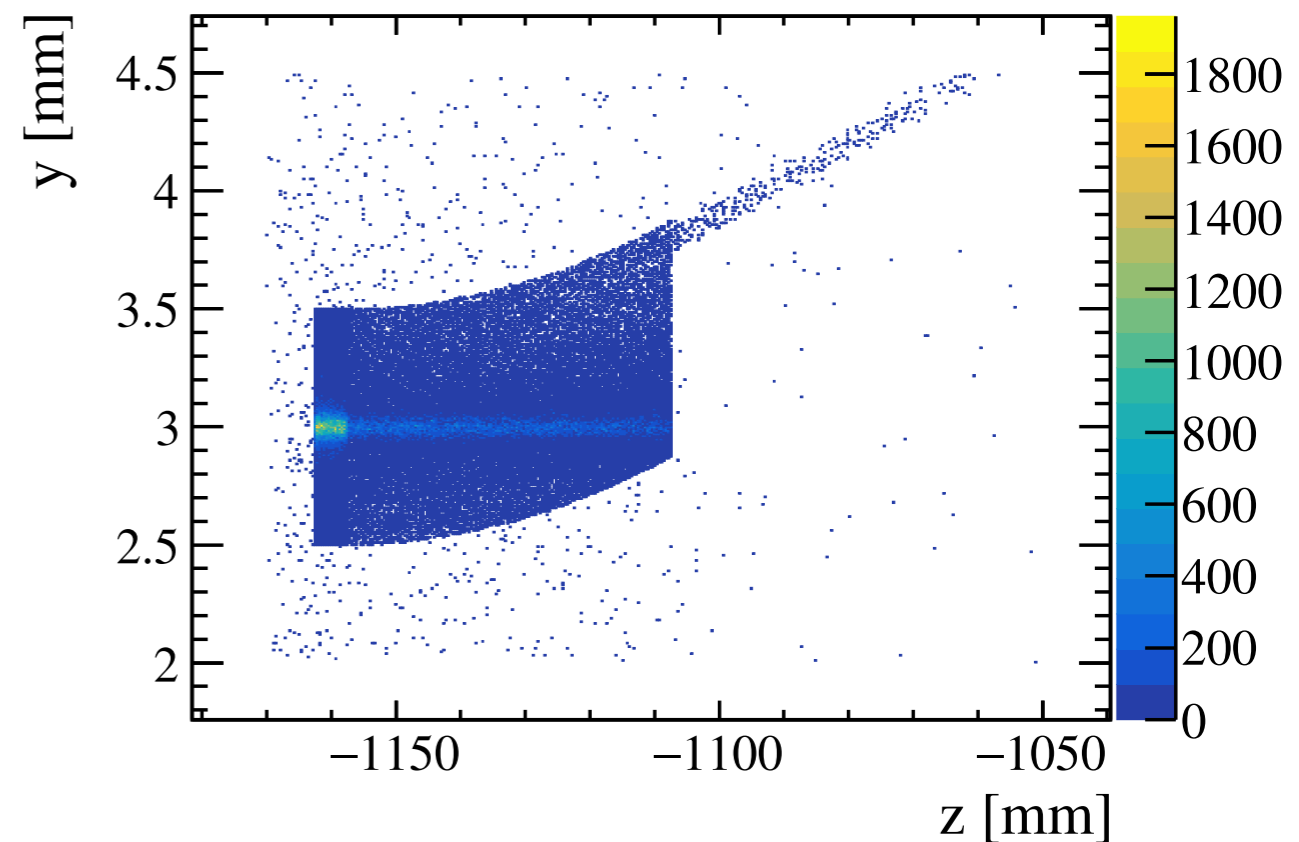
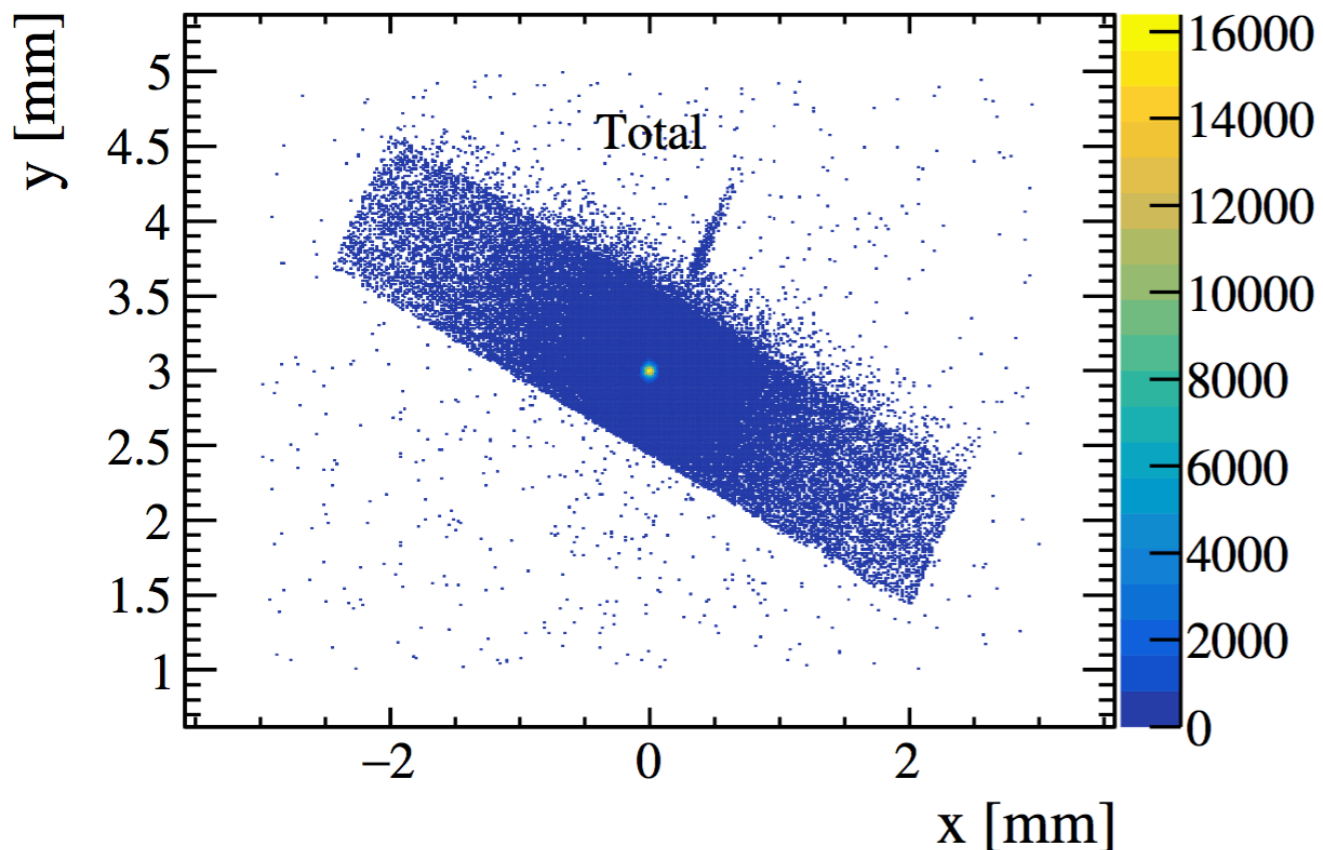

Identification of signal events

- ▶ About $10^{-4} \Lambda_c^+$ produced in the target are channeled in the bent crystal

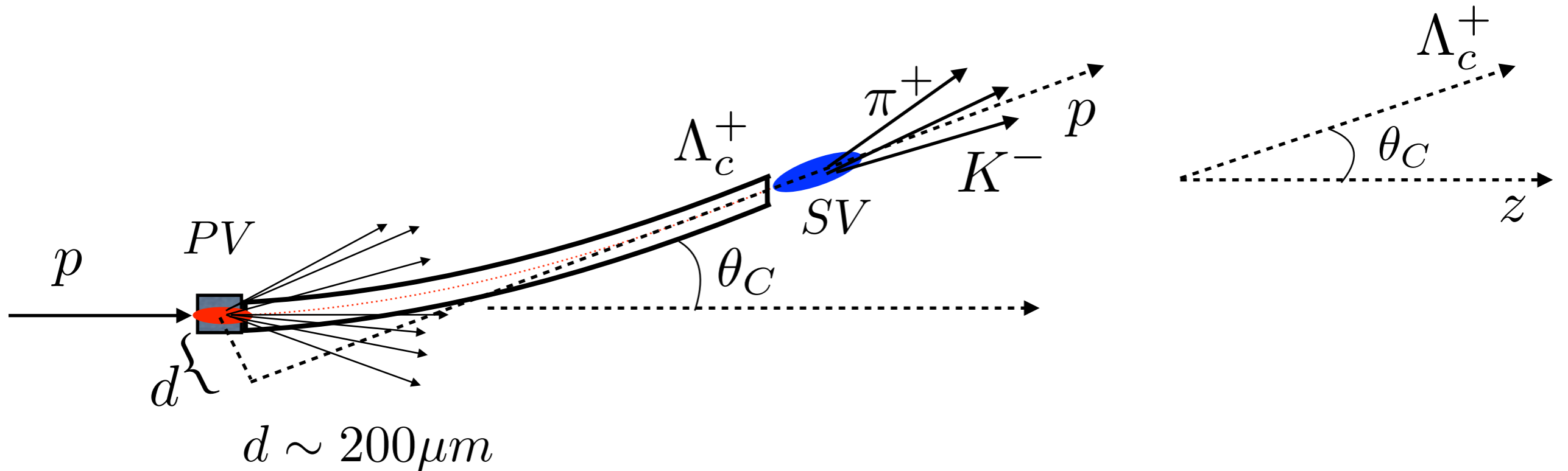

- ▶ Use **PV** to identify Λ_c^+ produced in W target, and Λ_c^+ vertex helps to identify decays outside of the crystal (max spin precession)
- ▶ **Λ_c^+ angle** determined by crystal bending angle, e.g. $\theta_C = 15$ mrad
- ▶ Channeled baryons have **high momentum $\gtrsim 1$ TeV/c**

Λ_c^+ momentum distribution

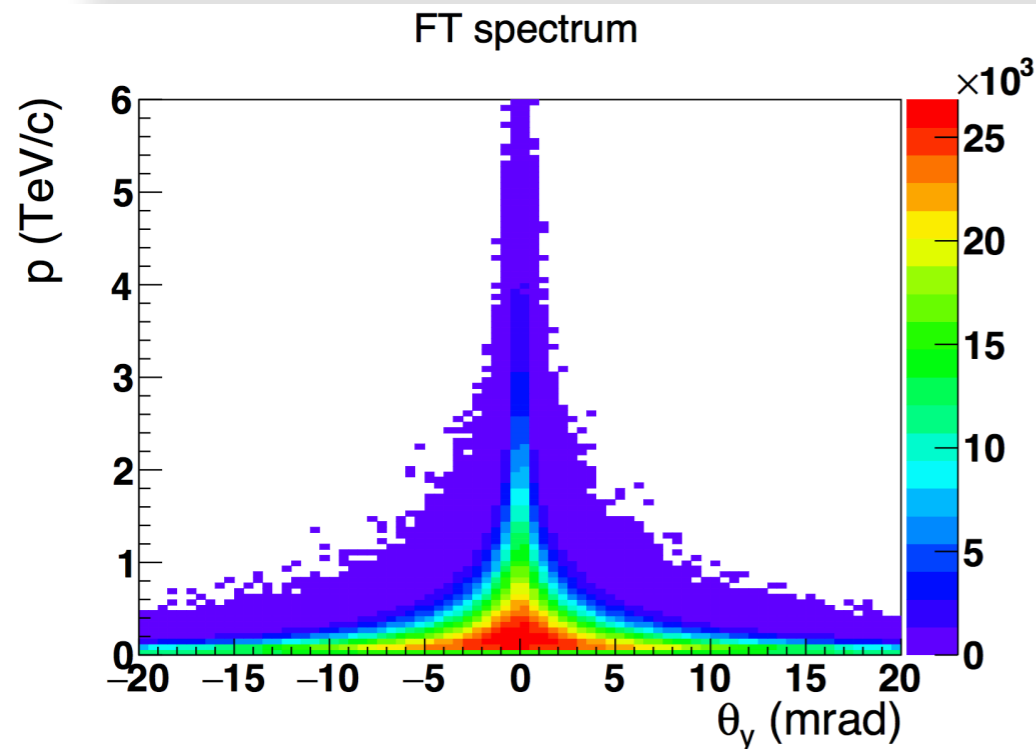

- ▶ At production (top)
- ▶ After channeling and $p > 800$ GeV/c (bottom)

Si, $L \sim 7$ cm, $\theta_c \sim 14$ mrad

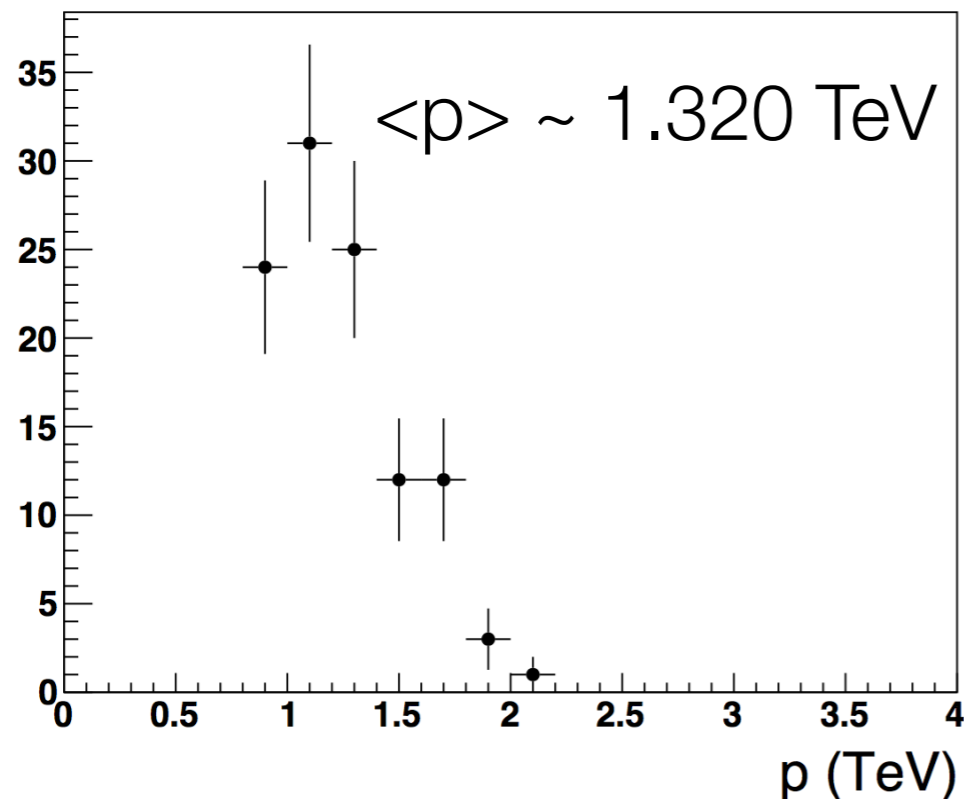

Ge, $L \sim 5$ cm, $\theta_c \sim 15$ mrad

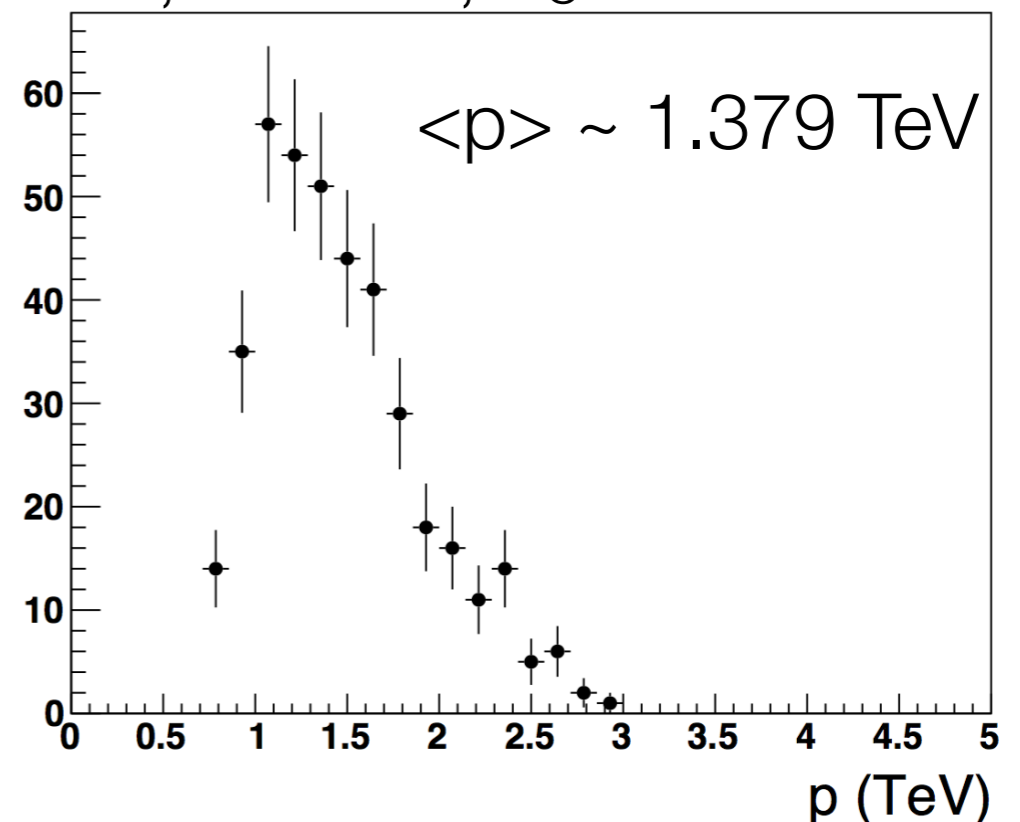

Background rejection

- ▶ Rejection of unchanneled Λ_c^+ produced in W target

Signal events

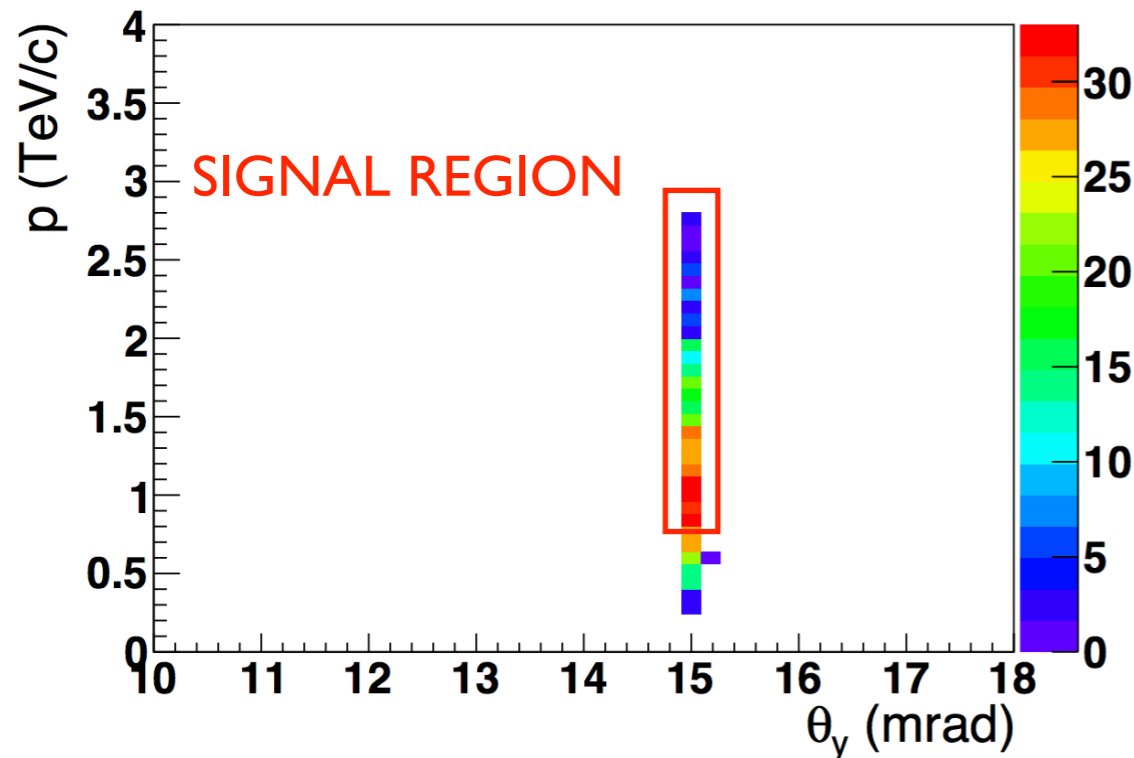

Crystal-transparent events

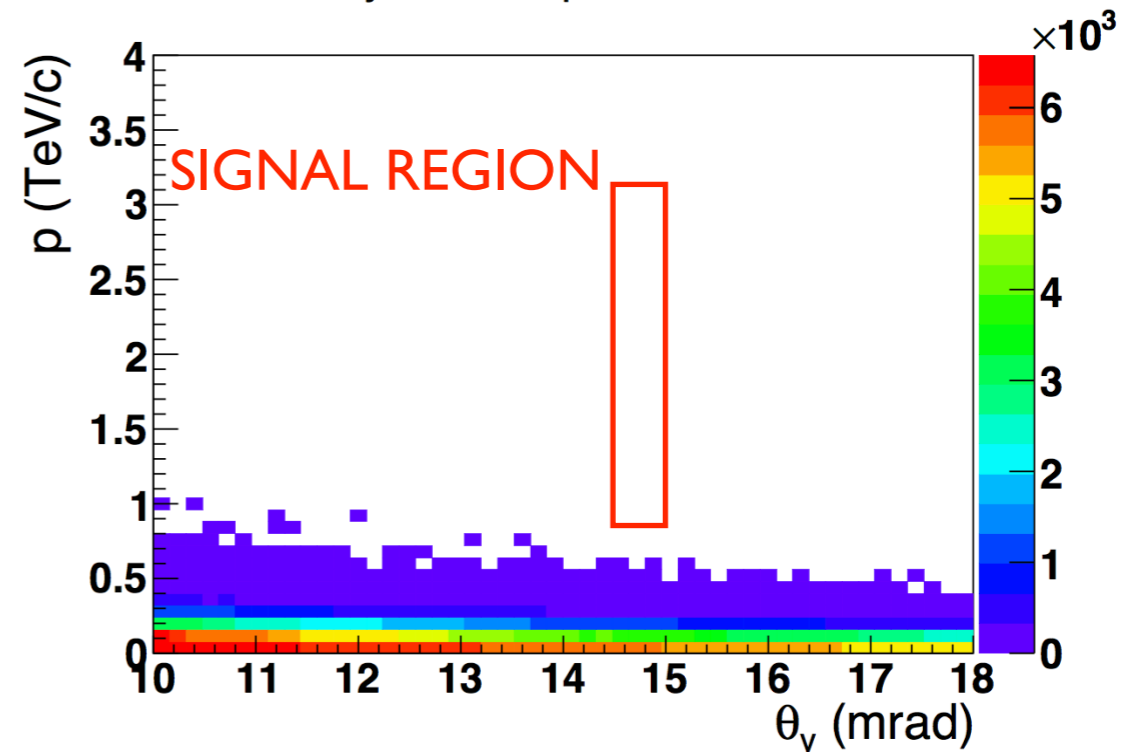

Channeled particles

Unchanneled particles

- ▶ Signal region: $14.8 < \theta < 15.2$ mrad [$\sigma(\theta) \sim 25 \mu\text{rad}$], $p_{\Lambda_c} > 800$ GeV/c
- ▶ Background rejection 10^{-7} level and signal efficiency 80%
- ▶ High momentum Λ_c^+ most sensitive for EDM measurements

EDM/MDM sensitivity studies

Intrinsic MDM of baryons

- $g \neq 2$ due to internal substructure, not point-like fermions
- From baryon MDM to quark MDM using quark model

$$\begin{aligned}\mu_p &= (4\mu_u - \mu_d)/3 \\ \mu_{\Sigma^+} &= (4\mu_u - \mu_s)/3 \\ \mu_{\Xi^0} &= (4\mu_s - \mu_u)/3 \\ \mu_{\Lambda} &= \mu_s\end{aligned}$$

$$\begin{aligned}\mu_n &= (4\mu_d - \mu_u)/3 \\ \mu_{\Sigma^-} &= (4\mu_d - \mu_s)/3 \\ \mu_{\Xi^-} &= (4\mu_s - \mu_d)/3 \\ \mu_{\Sigma^0} &= (2\mu_u + 2\mu_d - \mu_s)/3 \\ \mu_{\Omega^-} &= 3\mu_s\end{aligned}$$

$$\mu_q = \frac{Q_q \hbar}{2m_q} \quad \text{quark MDM}$$

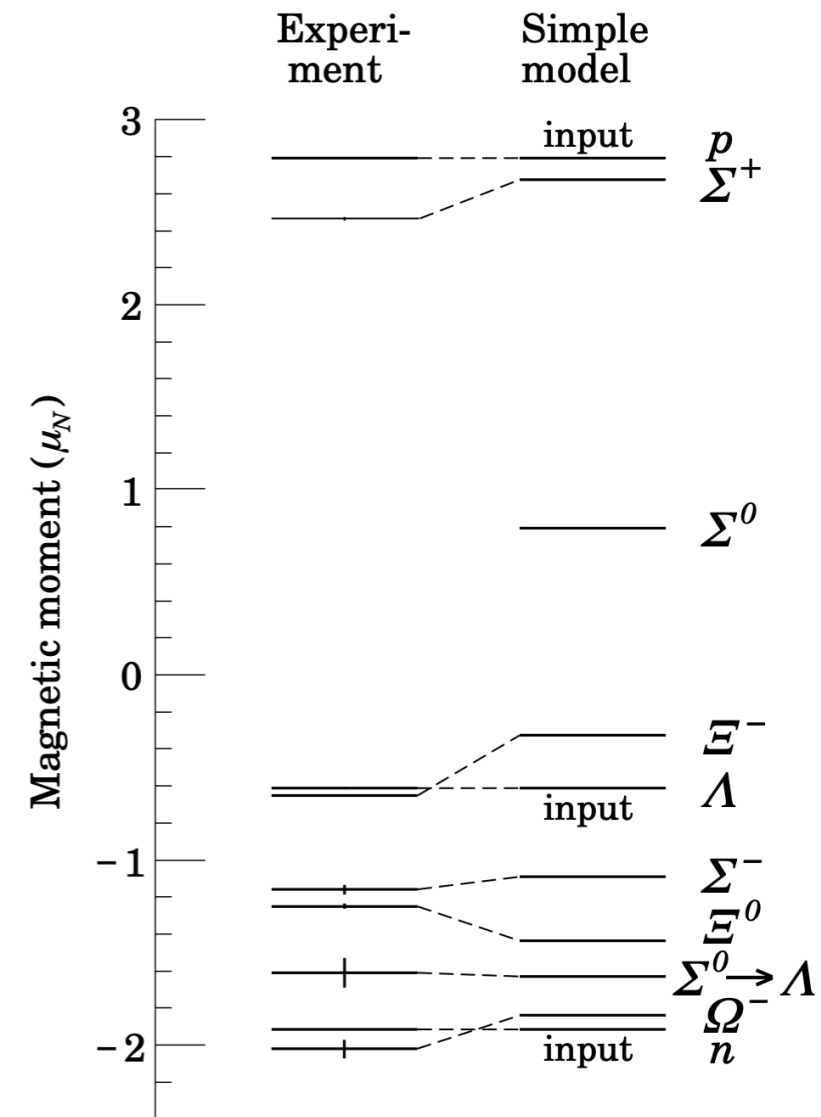
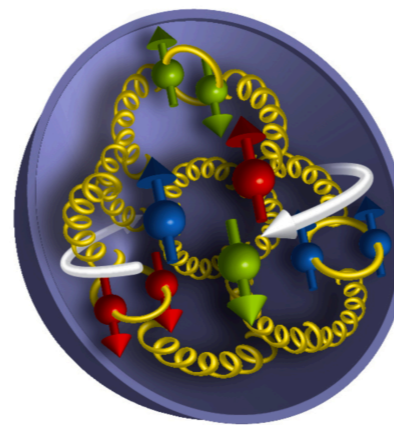

- ▶ Precise measurement of p MDM
- ▶ Test of CPT symmetry with \bar{p} MDM

$$\mu_p = 2.79284734462(82) \mu_N$$

G. Schneider et al., *Science* **358**, 1081 (2017)

$$\mu_{\bar{p}} = -2.7928473441(42) \mu_N$$

C. Smorra et al., *Nature* **550** (2017) 7676, 371-374

Heavy baryon EDM

- ▶ EDM of baryons from the structure of quarks and gluons, and processes with photon and flavour-diagonal coupling
- ▶ A measurement of a heavy baryon EDM is **directly sensitive** to:

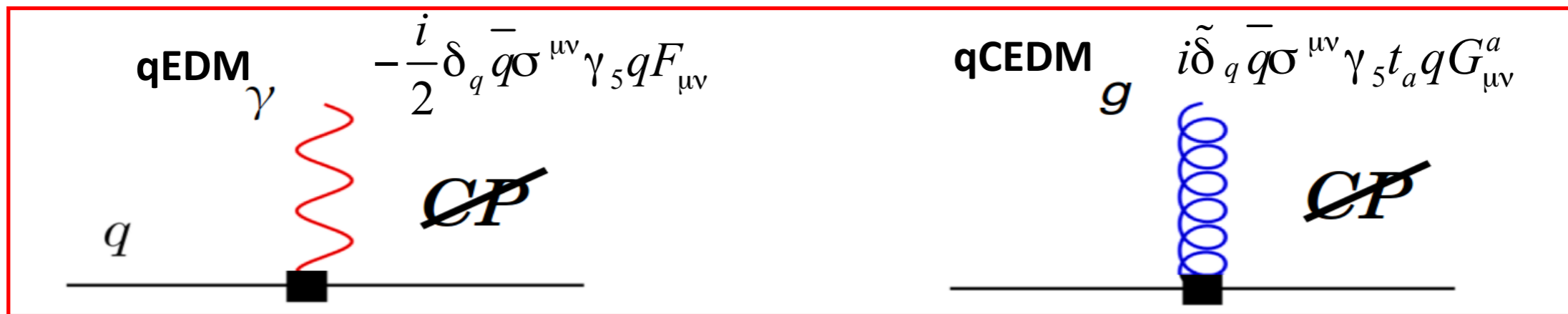

Charm EDM in SM-CKM $\sim 10^{-32}$ e cm
 Khriplovich, Lamoreaux (1997)

Charm EDM with new physics $\sim 5 \cdot 10^{-17}$ e cm
 EPJC 77 (2017), 102

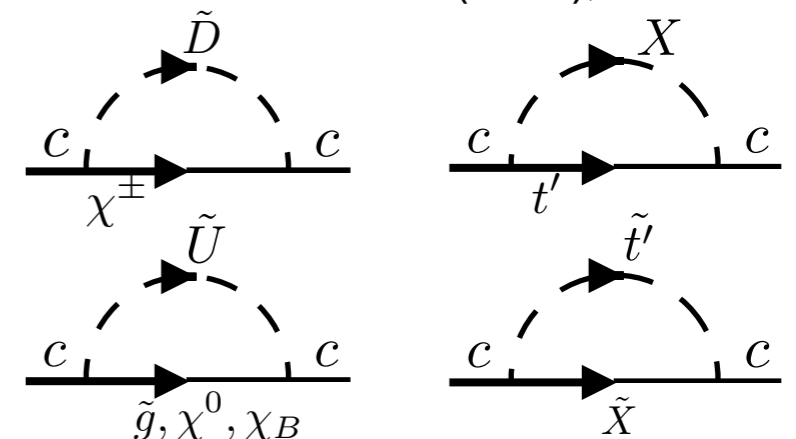
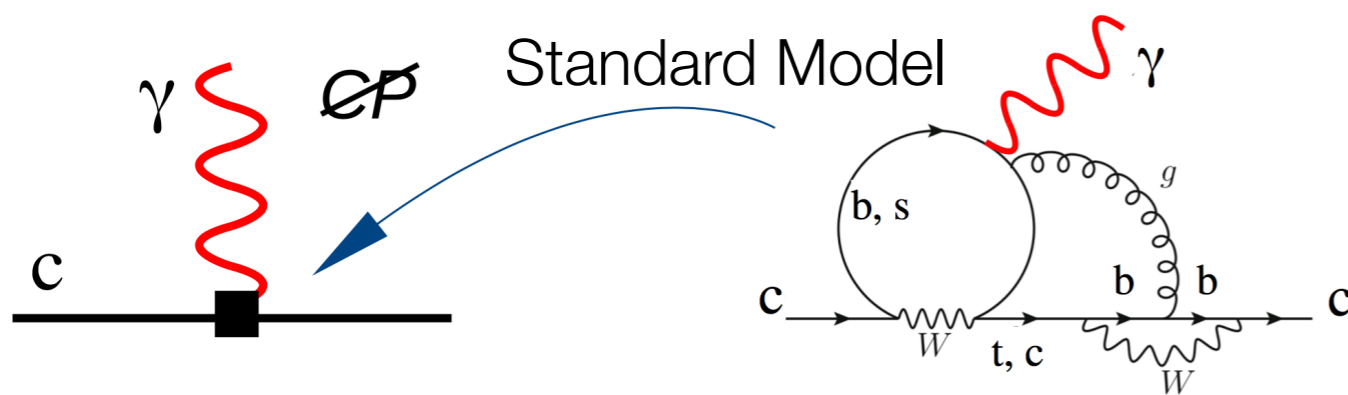

Heavy baryon **EDM** observation = clear signature of **new physics**

Sensitivity to EDM/MDM

► Studies based on:

- Λ_c^+ from fixed-target (Pythia + EvtGen)
- Reconstruction, Decay flight efficiency (LHCb simulation)
- Channeling efficiency (parametrization)
- Fit to spin precession (pseudo experiments)

$$N_{\Lambda_c^+}^{\text{reco}} = N_{\Lambda_c^+} \mathcal{B}(\Lambda_c^+ \rightarrow f) \epsilon_{\text{CH}} \epsilon_{\text{DF}} \epsilon_{\text{det}}$$

$$\sigma(pp \rightarrow \Lambda_c^+ X) \approx 18.2 \mu\text{b}$$

$$|S_0| \approx 0.6$$

$$\epsilon_{\text{det}} \approx 20\% \quad \epsilon_{\text{DF}} \approx 10\%$$

$$\epsilon_{\text{ch}} \approx 10^{-4}$$

$$\frac{dN}{d\Omega} \propto 1 + \alpha_f S \cdot p$$

$$\alpha_{\Delta^{++}K^-} \approx -0.67$$

$$\sigma_d \approx \frac{g-2}{\alpha_f s_0 (\cos \Phi - 1)} \frac{1}{\sqrt{N_{\Lambda_c^+}^{\text{reco}}}}$$

$$\sigma_g \approx \frac{2}{\alpha_f s_0 \gamma \theta_C} \frac{1}{\sqrt{N_{\Lambda_c^+}^{\text{reco}}}}$$

MDM/EDM via full amplitude analysis

- ▶ High statistics LHCb pp data sample to study Λ_c^+ , Ξ_c^+ decays
- ▶ Extract maximum information via full amplitude analysis of the 3-body decays D. Marangotto, AHEP (2020) 7463073

PRD 103, 072003 (2021)

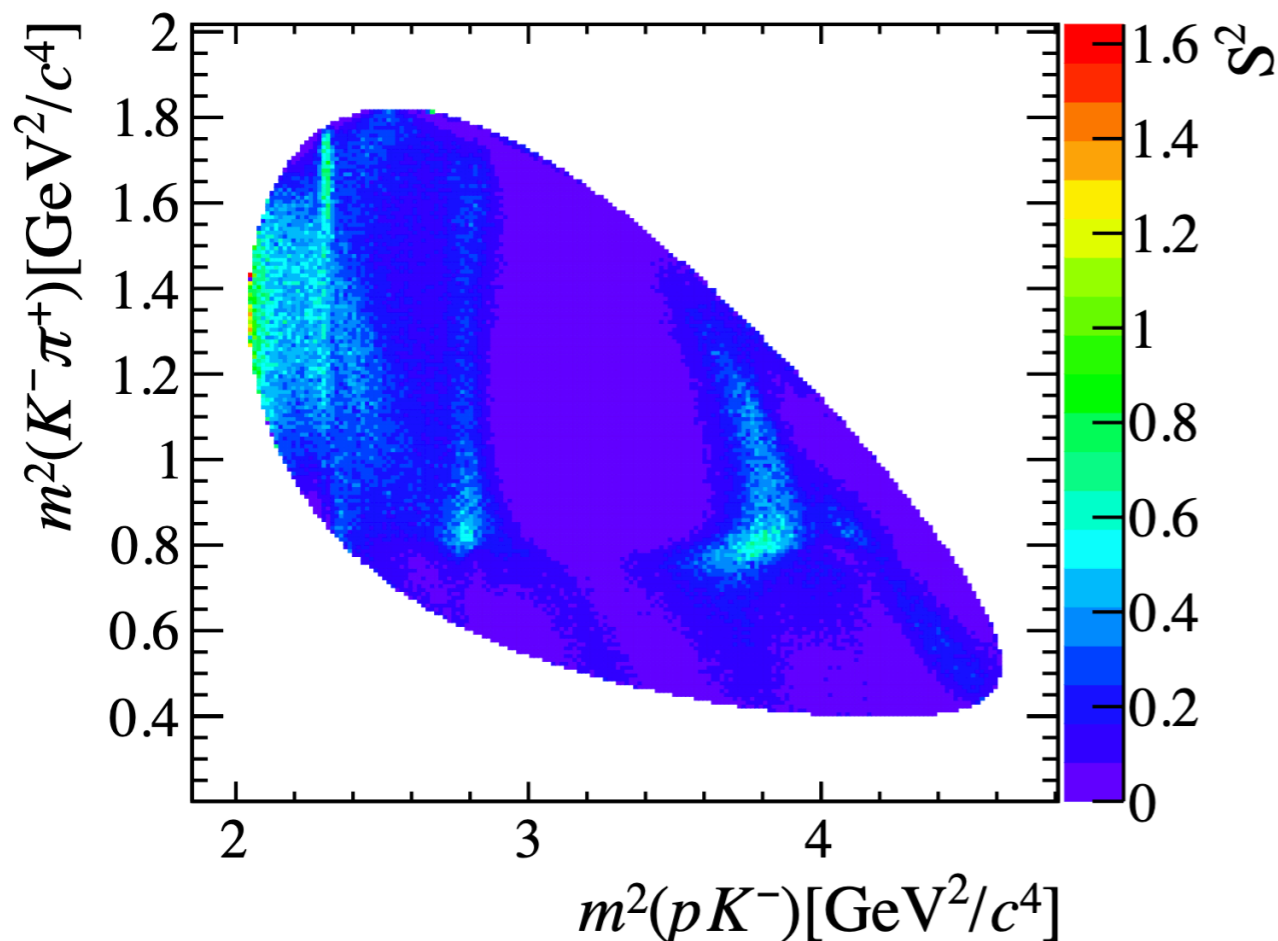

Decay distribution

$$W(\xi | s) = f(\xi) + s g(\xi)$$

ξ = phase space variable
 s = spin polarisation

Sensitivity: average event information

$$S^2 = \int \frac{g^2(\xi)}{f(\xi) + s_0 g(\xi)} d\xi$$

Crystal optimisation

- ▶ Optimised sensitivity to **MDM** and **EDM** for Ge crystal. Channeling and reconstruction efficiency included

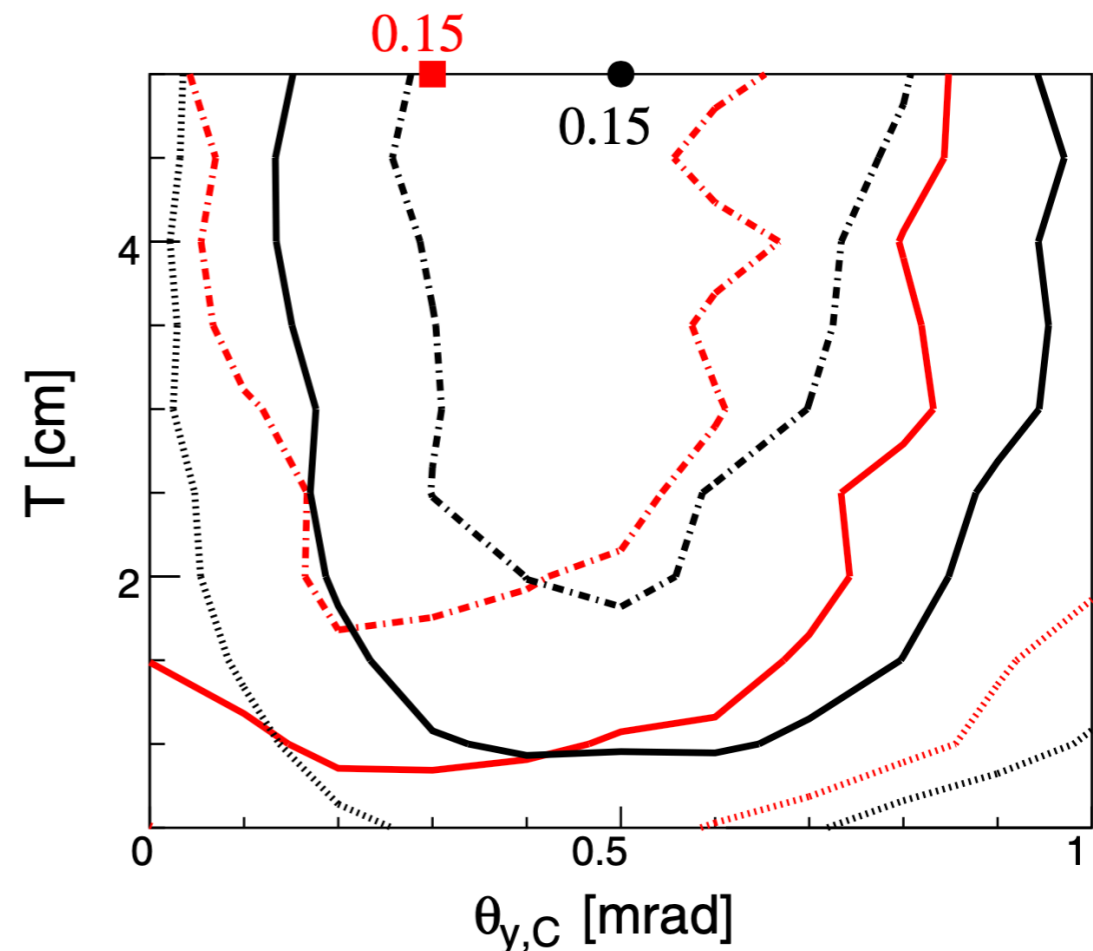
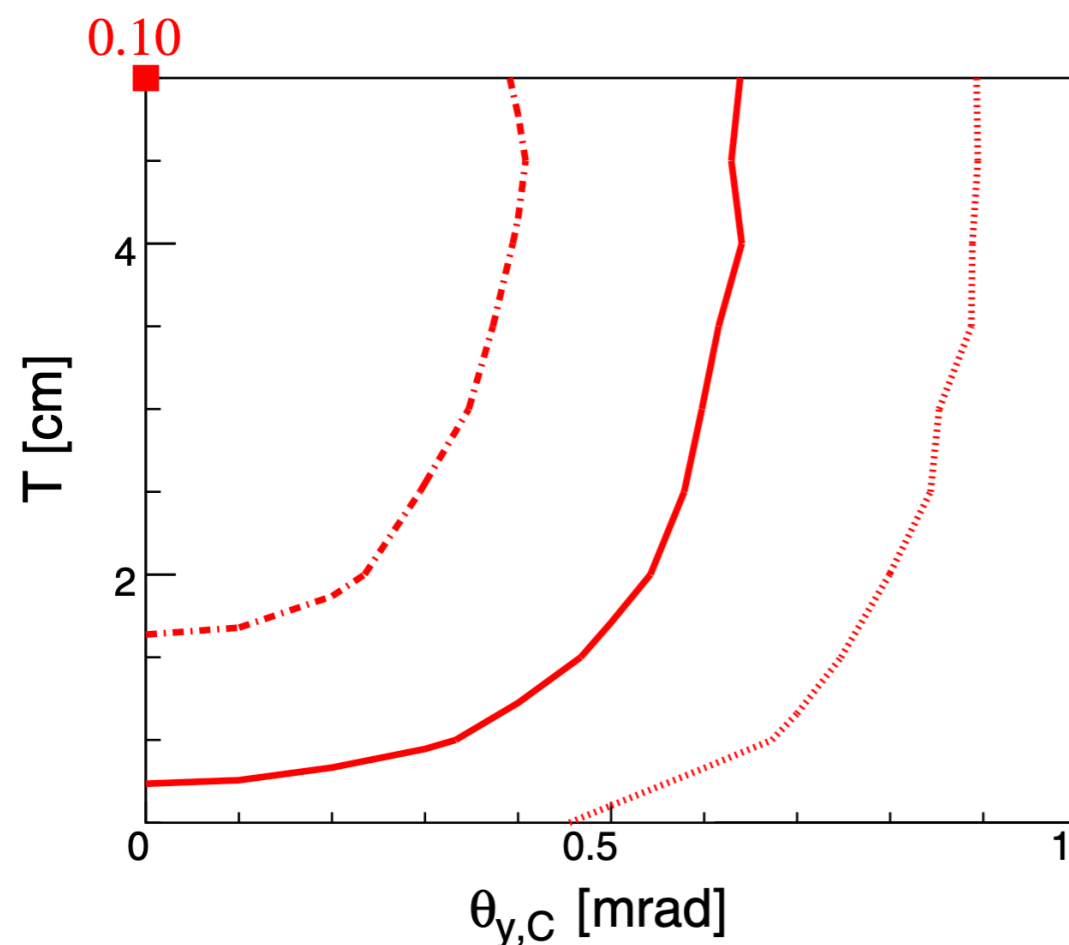

Regions of minimal uncertainty of **EDM** (black circle) and **MDM** (red square) defined as +20%, +50%, 100% uncertainty with respect to the minimum (point markers)

Future plans for τ lepton

Proposals for τ lepton

- A.S. Fomin , A. Korchin, A. Stocchi, S. Barsuk, P. Robbe, *Feasibility of τ lepton electromagnetic dipole moments measurements using bent crystals at LHC*, J. High Energ. Phys. 03 (2019) 156 (see backup slides)
- J. Fu, M. A. Giorgi, L. Henry, D. Marangotto, F. Martinez Vidal, A. Merli, N. N., J. Ruiz Vidal, *Novel method for the direct measurement of the τ lepton dipole moments*, Phys. Rev. Lett. 123, 011801 (2019)

Direct measurement of τ lepton dipole moments

- ▶ **Fixed-target** production: $D_s^+ \rightarrow \tau^+ \nu_\tau$ with $\tau^+ \rightarrow \pi^+ \pi^- \pi^+ \bar{\nu}_\tau$
- ▶ **Bent crystal** for spin precession

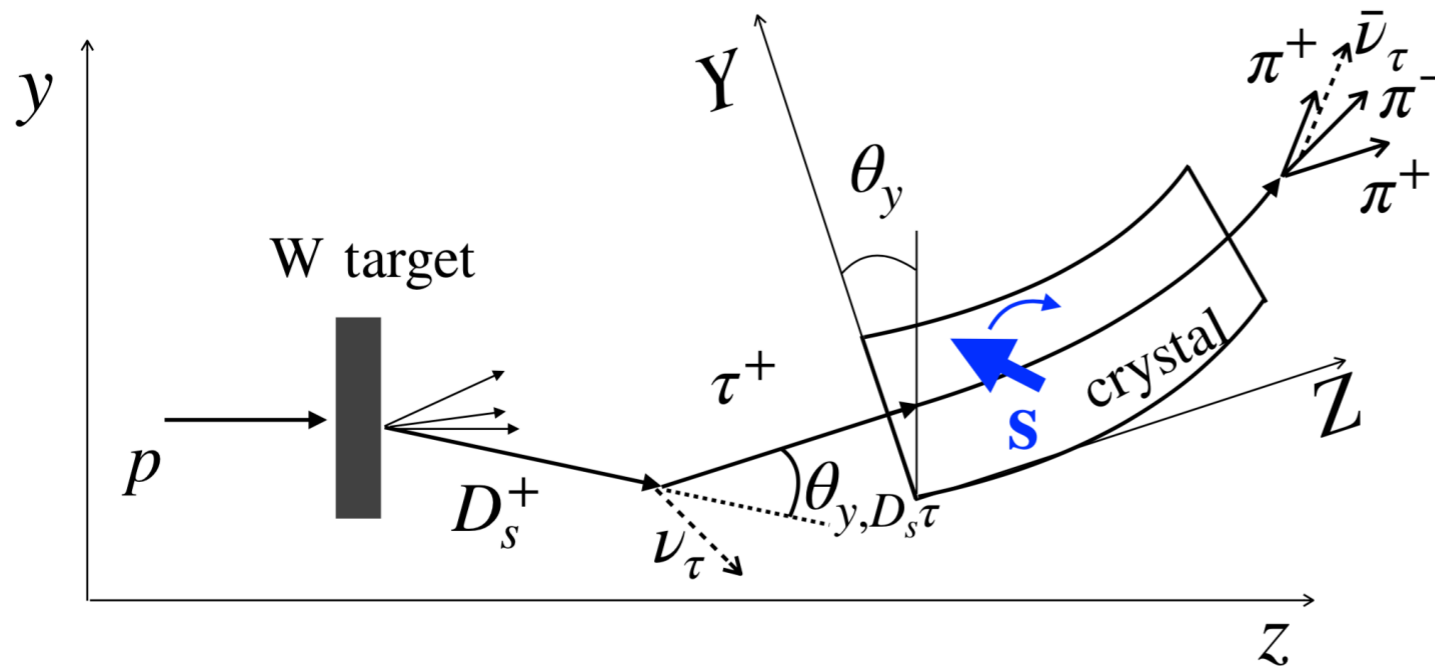

Spin polarisation

- kinematic selection on $p_{3\pi} > 0.8$ TeV, **longitudinal (z) polarisation** for MDM and enhanced EDM sensitivity
- Tagging $\theta(D_s, \tau) \leq 0$ (e.g. 2 crystals, other) **transverse (y) polarisation** for enhanced MDM sensitivity

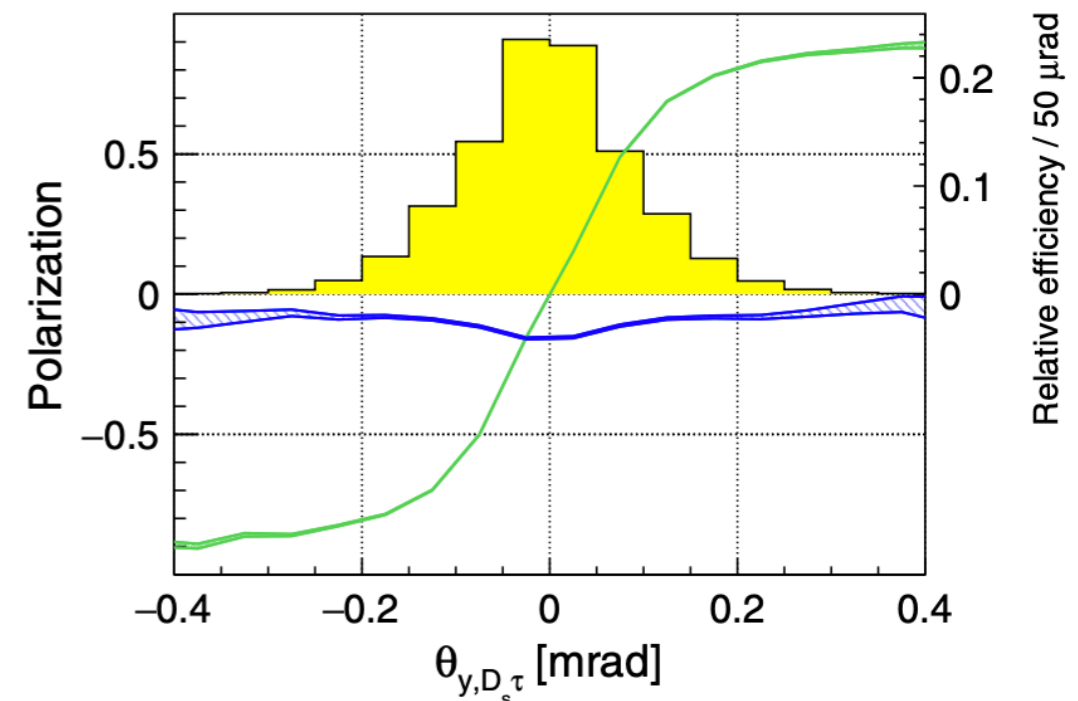
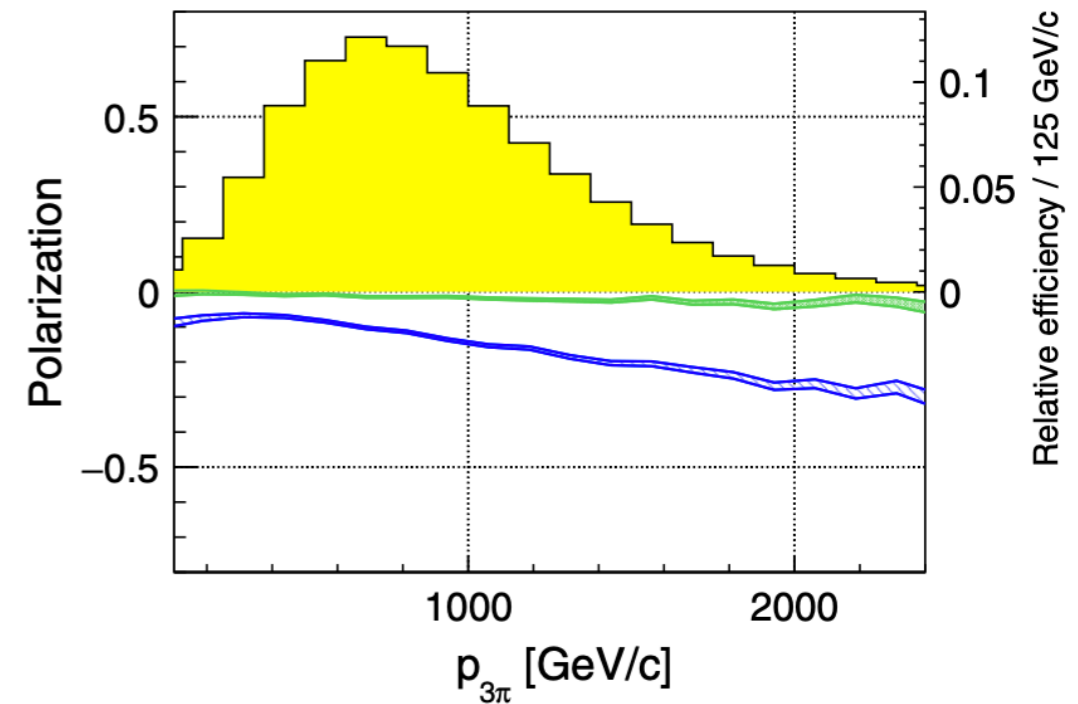

Sensitivity to dipole moments for τ lepton

Multivariate classifier based on reconstructed τ variables to determine the polarization and average event information $S=0.42$

$$S_i^2 = \frac{1}{N_{\tau^+}^{\text{rec}} \sigma_i^2} = \left\langle \left(\frac{\mathcal{W}_i^+(\eta) - \mathcal{W}_i^-(\eta)}{\mathcal{W}_i^+(\eta) + \mathcal{W}_i^-(\eta)} \right)^2 \right\rangle$$

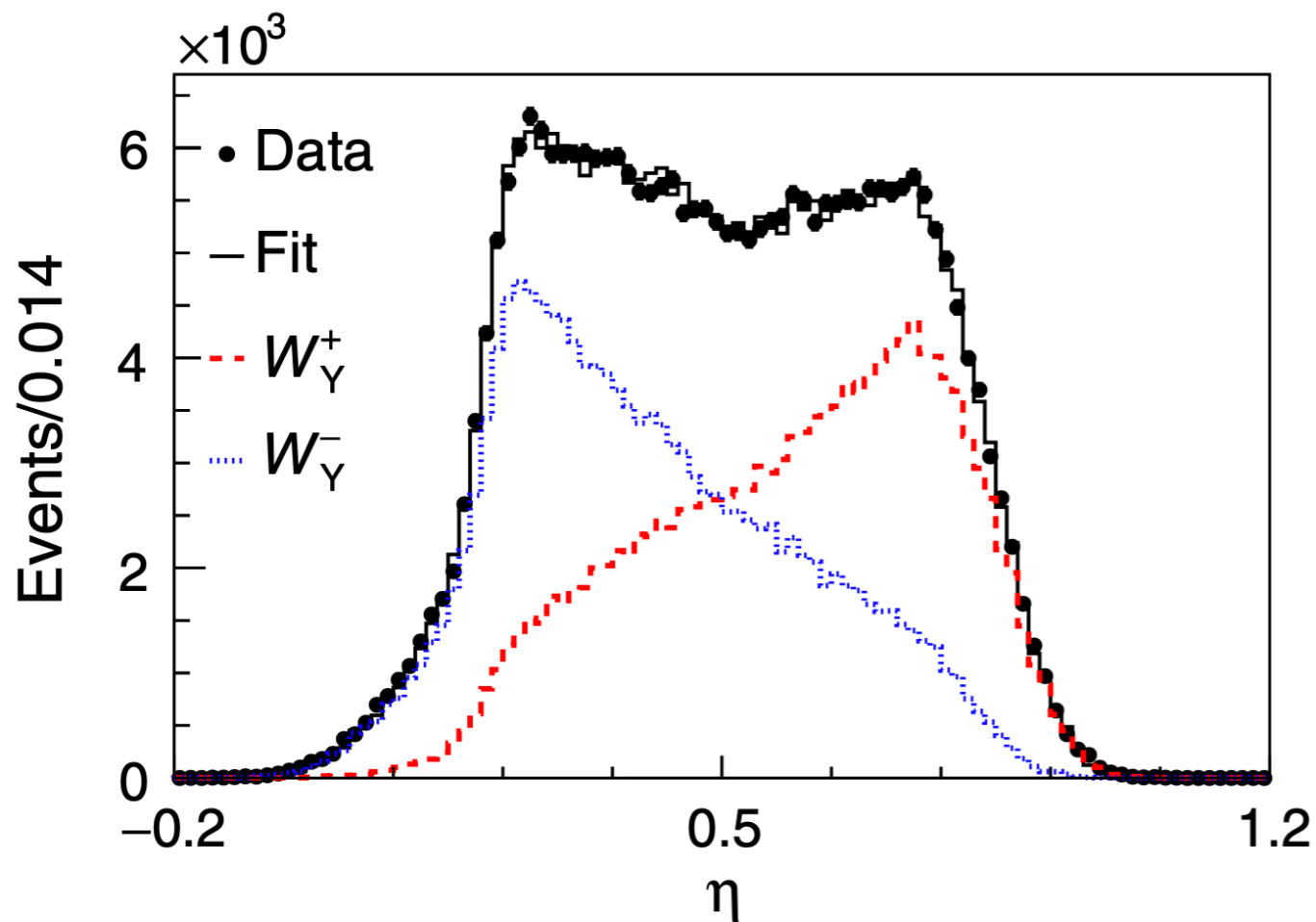

Phys. Rev. Lett. 123, 011801 (2019)

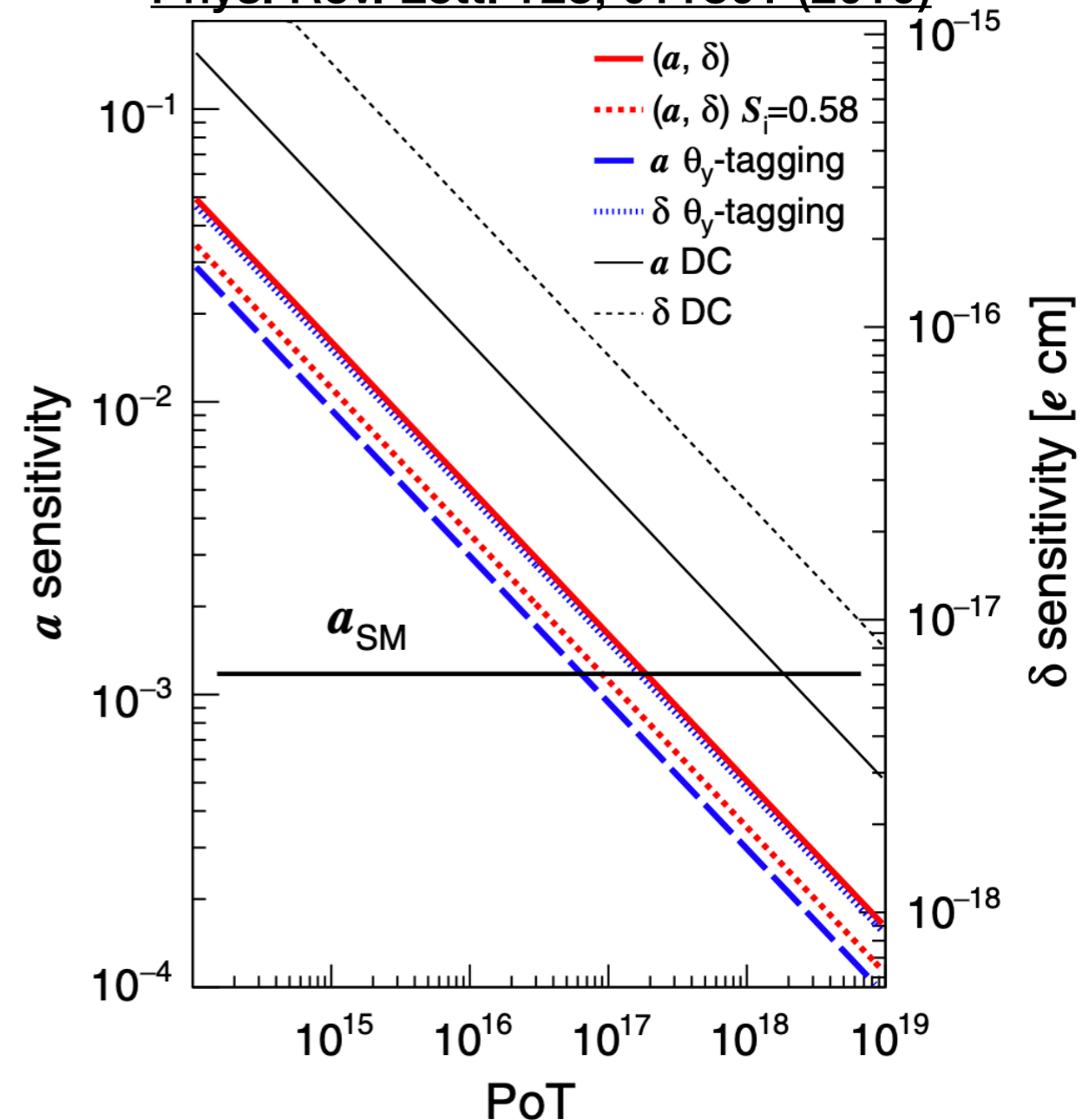

Test $g-2$ SM prediction with $\sim 10^{17}$ PoT

EDM sensitivity $\sim 10^{-17}$ e cm

Challenging: **dedicated experiment** needed

Future plans

- ▶ New proposals for τ lepton MDM/EDM direct determination using bent crystals
- A.S. Fomin , A. Korchin, A. Stocchi, S. Barsuk, P. Robbe, *Feasibility of τ lepton electromagnetic dipole moments measurements using bent crystals at LHC*, arXiv:1810.06699
- J. Fu, M. A. Giorgi, L. Henry, D. Marangotto, F. Martinez Vidal, A. Merli, N. Neri, J. Ruiz Vidal, *Novel method for the direct measurement of the τ lepton dipole moments*, arXiv:1901.04003
- ▶ Large statistics needed for interesting measurements, i.e. $PoT \gtrsim 10^{17}$ [2.5 cm W target]
- ▶ Many challenges: dedicated experiment needed
- ▶ Preparatory studies in LHCb

Feasibility of τ lepton electromagnetic dipole moments measurement using bent crystal at the LHC

Crystal 1:

- directing a part of LHC primary halo on Target

Target:

- production of $D_s^+(\rightarrow\tau^+u_\tau)$
 $\tau^+ \rightarrow \pi^+\pi^-\pi^+\bar{\nu}_\tau$

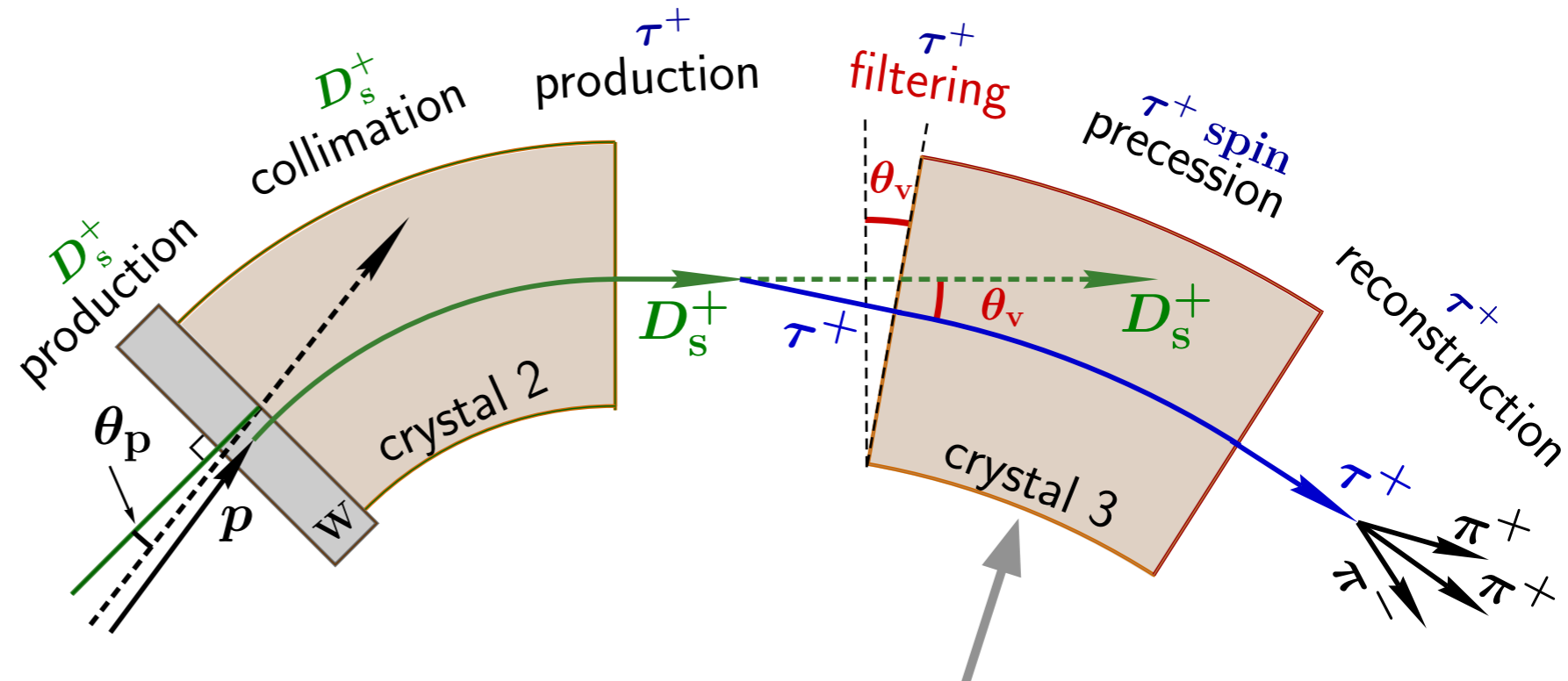

Crystal 2:

- deflection and “collimation” of D_s^+

Crystal 3:

- selecting τ produced by D_s^+
- **filtering τ initial polarisation**
- τ spin precession

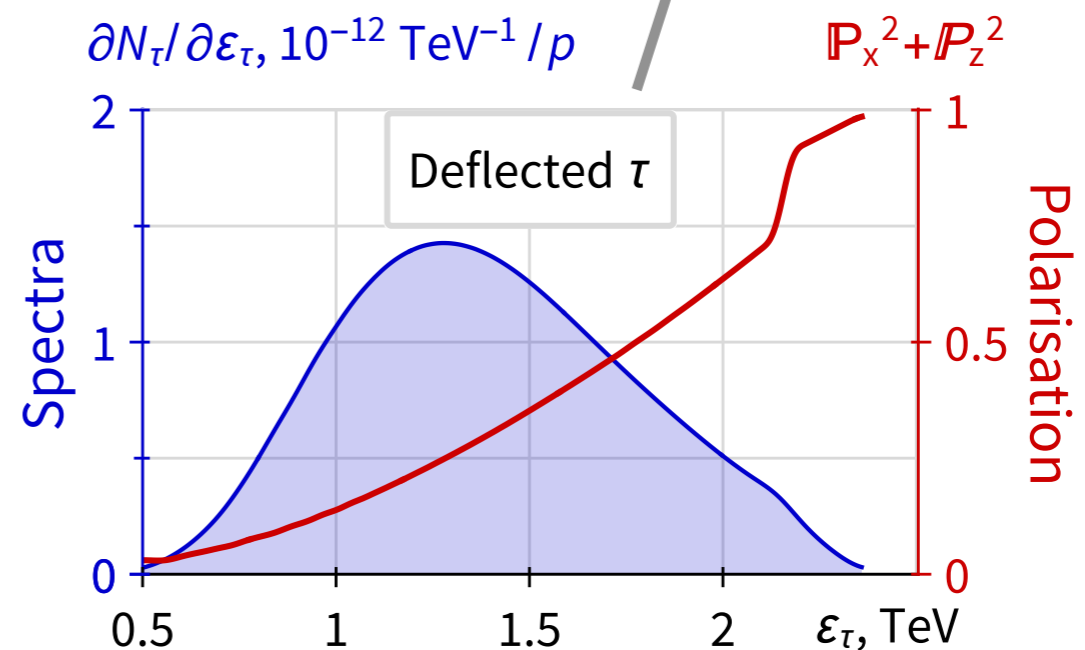

Feasibility of τ lepton electromagnetic dipole moments measurement using bent crystal at the LHC

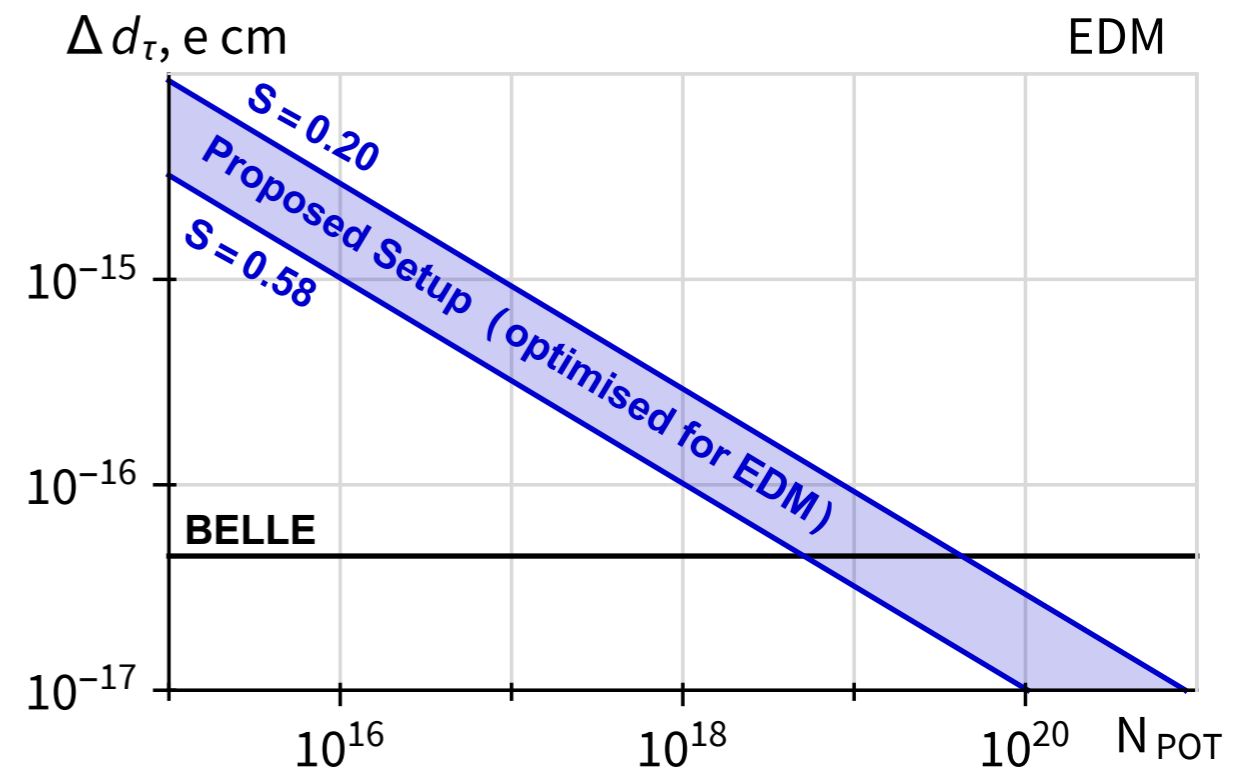
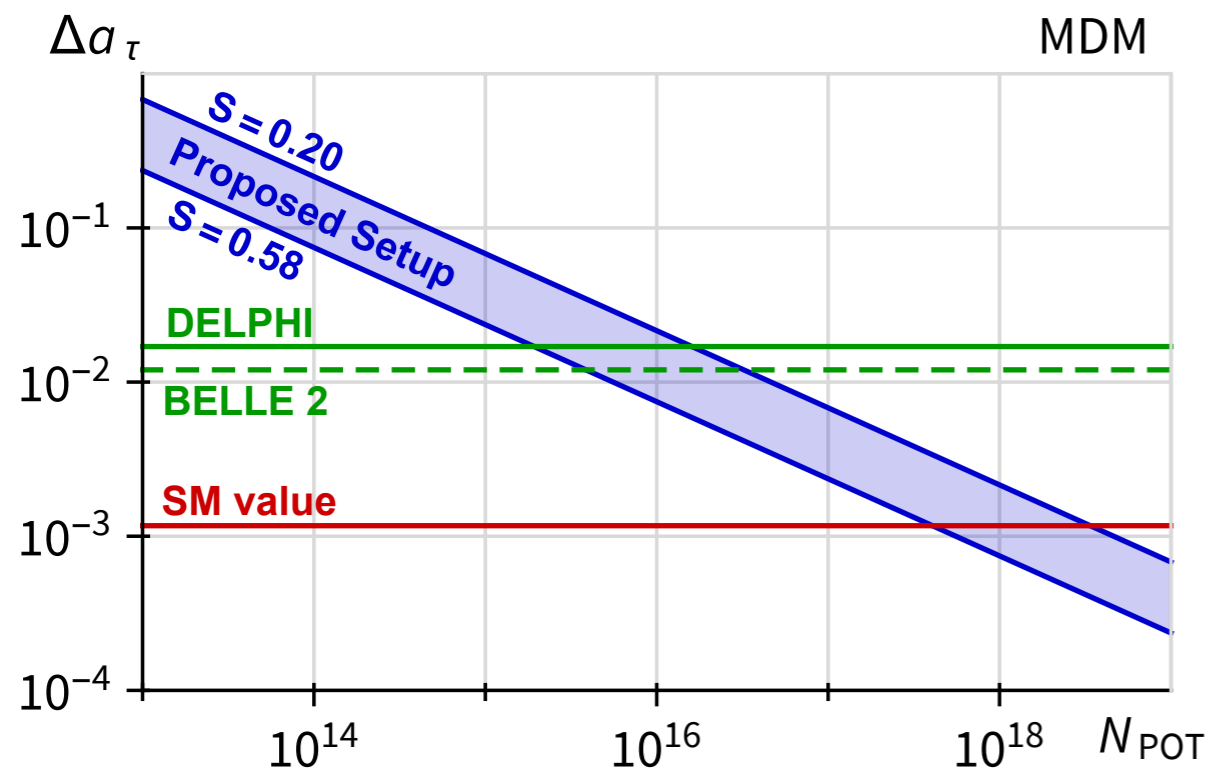

MDM: 10^{16} PoT — to reach the present accuracy [DELPHI: J. Abdallah et al. EPJC 35:159–170, 2004]

10^{18} PoT — to reach an accuracy equivalent to the **Standard Model value**

EDM: 10^{19} PoT — to reach the present accuracy [BELLE: K. Inami et al. PLB 551:16–26, 2003]